

Round Cube (Mini 2.4)



Read the manual and check the parts for completeness before assembly!

Images are illustrative and may differ from reality, the construction principle is the same.

USER MANUAL OF THE SAUNA

1. It is recommended to install the sauna above ground level to prevent the legs of the sauna from coming into direct contact with the ground. Install a water-resistant material, such as bitumen strips, between the legs of the sauna and the base.
2. Make sure that the surface on which you install the sauna is leveled and stable both before and after installing the sauna. Otherwise, the doors of the sauna may not open and close properly.
3. If the top part of the chimney has not been installed upon delivery of the sauna, it should be placed into the chimney pipe from the roof of the sauna.
4. During the first heating of the sauna, it must be constantly supervised and the doors should be kept open, as the stove emits a specific smell when first heated. Read more from the user manual of the sauna stove.
5. The maximum permitted temperature of the steam room is +90 °C. If heated to a higher temperature, the sauna may be overheated.
6. After each use of the sauna, it is recommended to keep the stove warm, the doors open, and the footrests up for a while to allow the sauna to dry from the inside. If necessary, the water on the floor should be directed to the drain with a floor scraper to avoid damage caused by excess humidity.
7. **When the weather is humid and if the wood has expanded, the metal hoops around the sauna should be loosened to avoid breaking the clamps and jamming the doors.** The hoops can be adjusted from the nut of clamp M12 located on the side of the sauna. To alleviate excess tension on the clamp and the hoop itself, loosen nut M12 (wrench no. 19) until the hoop can be shifted left and right. Then, re-tighten the nut until the hoop is under slight pressure and pressed fully against the wood so that it cannot be pulled away from the walls of the sauna. **When the weather is less humid and the wood has dried, the metal hoops around the sauna should be tightened from nut M12.** Tighten the nut so the hoop is under slight pressure. The hoop must be pressed fully against the wood so that it cannot be pulled away from the walls of the sauna. **LEIL SAUNAS is not liable for damage caused to the sauna due to a broken hoop clamp.**
8. If the door is shifted out of place when the hoops are tightened, lift the exterior door off the hinges and regulate the hinges. If this is not a sufficient solution, remove the trims of the door and unscrew the screws of the doorframe beneath them. This will relieve the pressure on the door. If necessary, the opening of the door may be made wider, after which the screws should be re-tightened and the trims and door reinstalled.
9. The interior door should be regulated from the stopper and, if necessary, the hinges. If this is not a sufficient solution, remove the trims of the door and unscrew the screws of the doorframe beneath them. This will relieve the pressure on the door.
10. Locking the sauna door from the inside is prohibited.
11. In order to avoid damage caused by the weight of snow, any snow should be removed from the roof of the sauna. Keep in mind that the roof covering should not be damaged during snow removal.
12. If your sauna has lighting, install a 3G 2,5 mm² outdoor power cable and connect it in junction box provided with the sauna (L1 – brown , N – blue , GR – green-yellow). The power cable of the sauna must be connected to a residual-current circuit breaker! Consult an electrician if necessary.

Maintenance of the sauna

1. **The interior surfaces of the sauna, the window frames of the steam and washing room, and the frames of interior doors must be treated with a special substance before initial use to protect them from humidity and dirt and extend the useful life of the sauna.** Later, this should be done once or twice a year. TEKNOS Satu Saunasuoja or Tikkurila Supi Saunasuoja may be used for this.
2. **Before initial use of the sauna, the benches and footrests must be treated with a protective oil to extend their useful life.** Later, this should be done once or twice a year. TEKNOS Satu Laudesuoja or Tikkurila Supi Laudesuoja or something similar high-temperature resistant interior wood varnish may be used for this.
3. **The exterior surfaces of the sauna are given the first protective coating during production (DIY saunas are not treated). The second coating should be applied approximately two months after purchasing the sauna to extend its useful life and maintain its appearance.** Remmers Aidol HK-Lasur or something similar weather-resistant exterior wood varnish may be used for this.
4. **LEIL SAUNAS is not liable for damage caused to the sauna due to insufficient maintenance or no maintenance at all.**

WARRANTY

- The products have a 24-month warranty covering material and production defects, taking effect from the delivery of the sauna to the client.
- The warranty is valid if the user has reviewed the user manuals and abides by them.
- Please note! The warranty period differs for products on trailers and products intended for commercial use.
- The warranty does not cover defects characteristic of wood, such as discoloration, changes, issues, or cracks caused by alternating or excess humidity, etc.
- The warranty does not cover cracking of the bitumen sealant between the roof covering and the end arches due to drying of the wooden material. If the sealant cracks, the old sealant must be replaced with a new one (ROOF REPAIR SEALANT SOUDAL ROOF REPAIR 310 or similar).
- The warranty does not cover normal wear and tear of the product caused by its use and damage caused by incorrect installation or use is not compensated.
- The warranty does not cover damage caused by thunder or other weather phenomena.
- The warranty does not cover damage caused by incorrect installation by the client.
- The warranty expires when attempts are made to independently change or fix the product or if it is not used for its intended purpose.
- The warranty is void if the product is stored in an incorrect position or in the wrong conditions.
- The warranty is valid if the buyer informs the seller of the defect within a reasonable time (7 days).

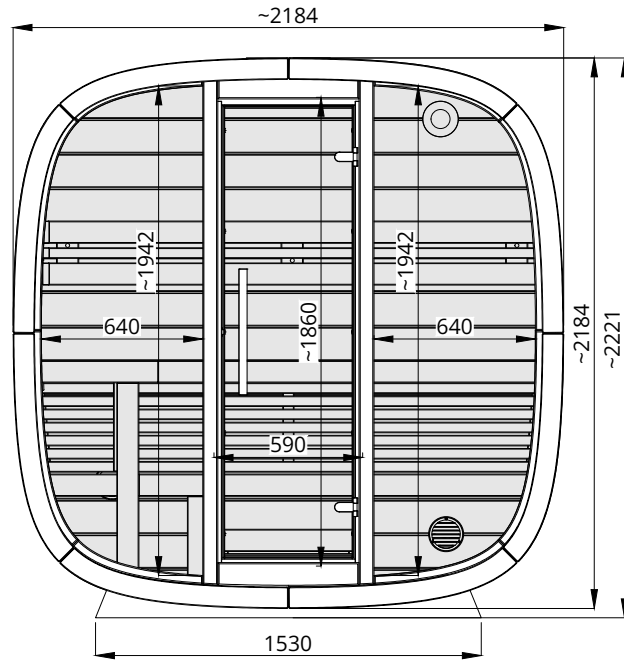

Front view

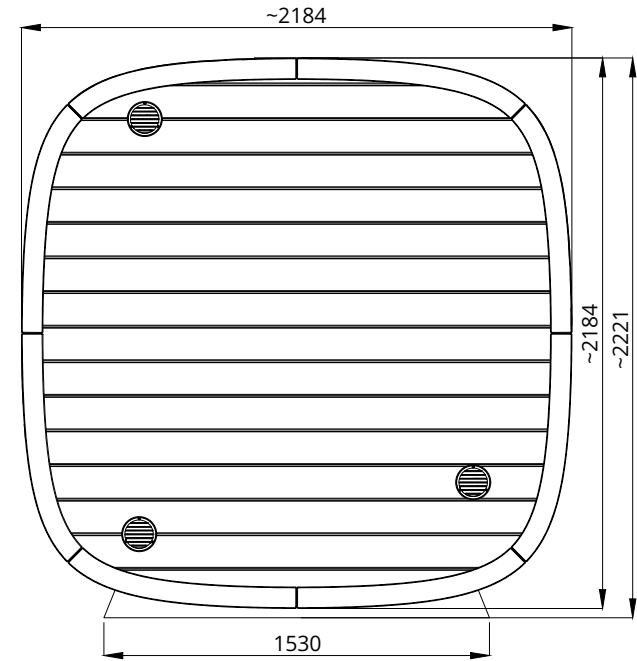

Back view

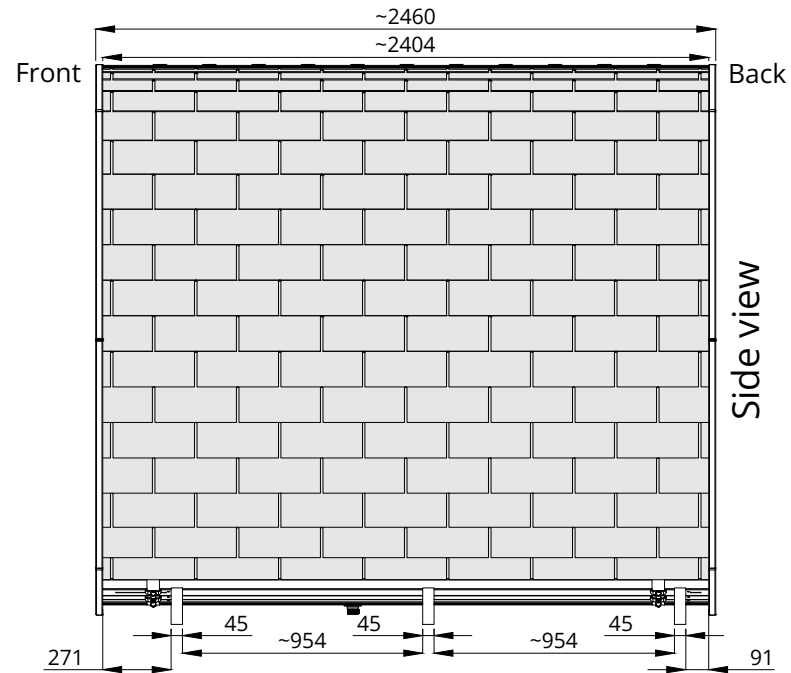

Round Cube

(MINI 2.4)

Scale 1 : 30

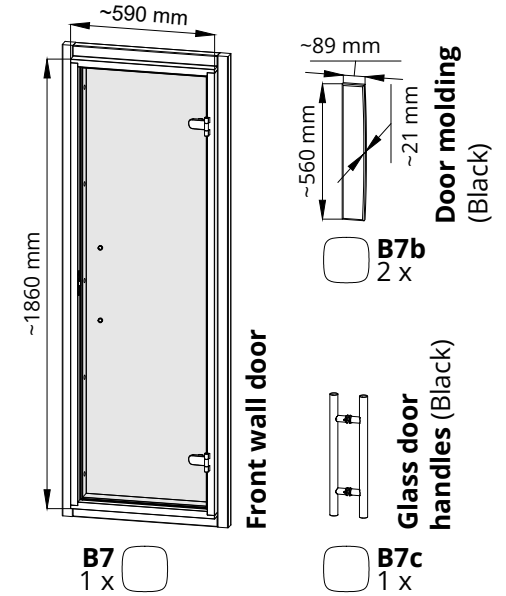
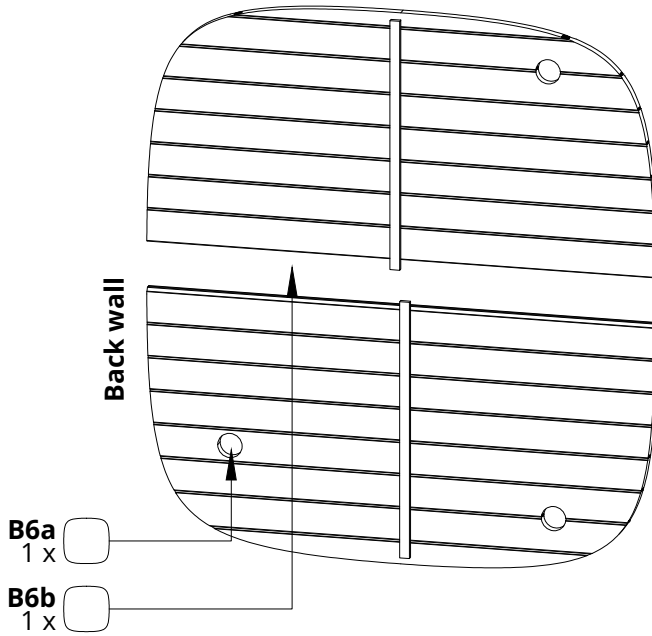
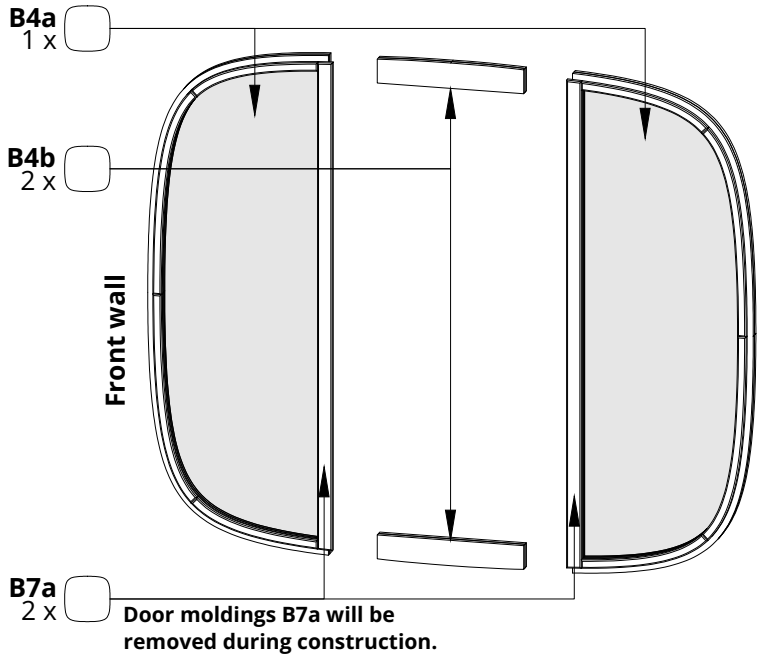

Round Cube (MINI 2.4)	
a	~2042 mm
b	~2404 mm

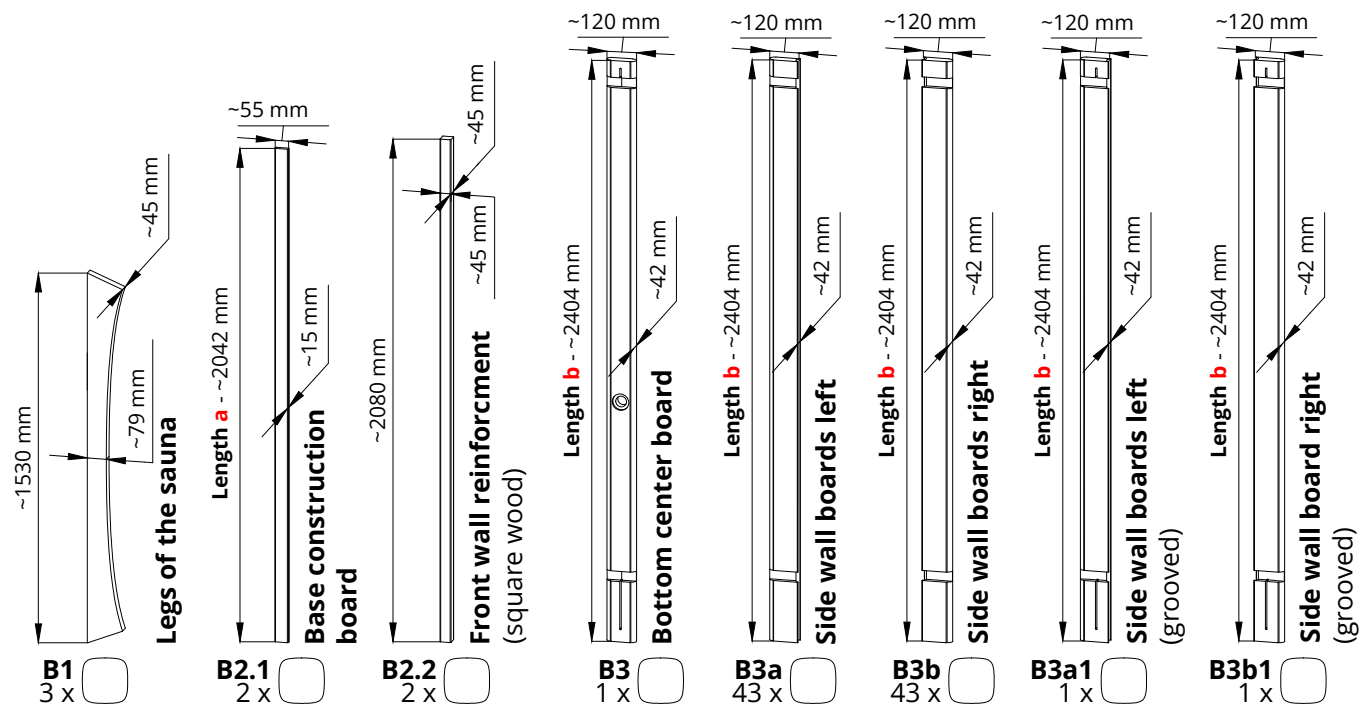

Detail list 1

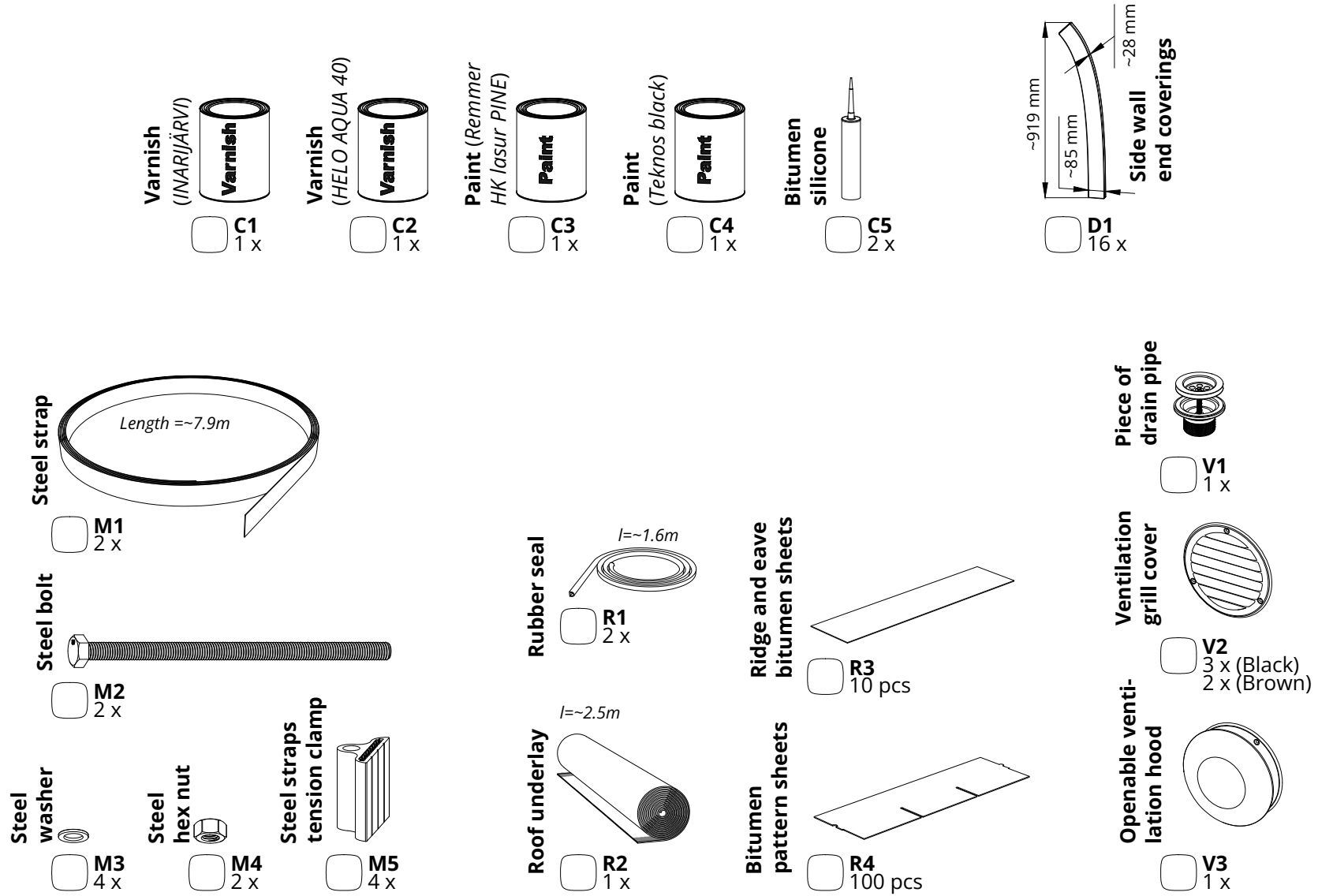

Detail list 2

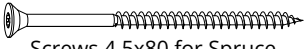
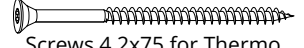
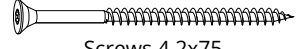
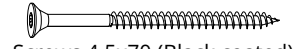
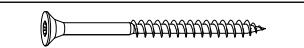
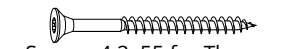
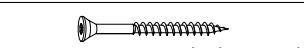
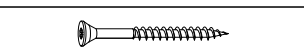
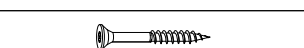
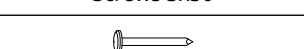
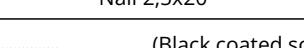
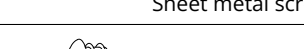
Name in manual	Nails and screws / Screw size (Scale 1:2)	Area of use	Quantity	
S7	 Screws 4,5x80 for Spruce	Mainly for construction inside and outside	60	<input type="checkbox"/>
	 Screws 4,2x75 for Thermo			
S6.2	 Screws 4,2x75	For fixing the door(s)	20	<input type="checkbox"/>
S6.1	 Screws 4,5x70 (Black coated)	For fixing the side wall end coverings	50	<input type="checkbox"/>
S5	 Screws 4,5x60 for Spruce	Mainly for construction inside and outside	140	<input type="checkbox"/>
	 Screws 4,2x55 for Thermo			
S3.2	 Screws 4,5x50 (Black coated)	For fixing door moldings <i>(screws is attached to the door moldings)</i>	20	<input type="checkbox"/>
S2	 Screws 3x40	Mainly for construction inside and outside	10	<input type="checkbox"/>
S1	 Screws 3x30	Mainly for construction inside and outside	20	<input type="checkbox"/>
R5	 Nail 2,5x20	During roof installation	1kg	<input type="checkbox"/>
R6	 (Black coated screw head) Sheet metal screw 4,2x25	During roof installation	100	<input type="checkbox"/>
P	 Hole plug	For covering screw holes	20	<input type="checkbox"/>

Detail list 3

S7	Screws 4,5x80 for Spruce Screws 4,2x75 for Thermo	6
		

NB! use a level

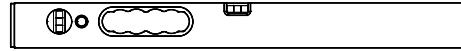

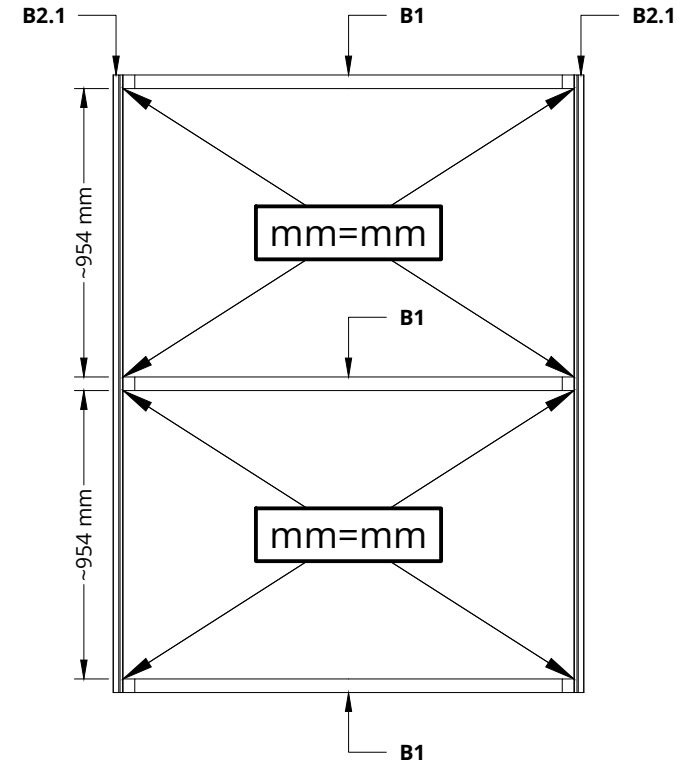
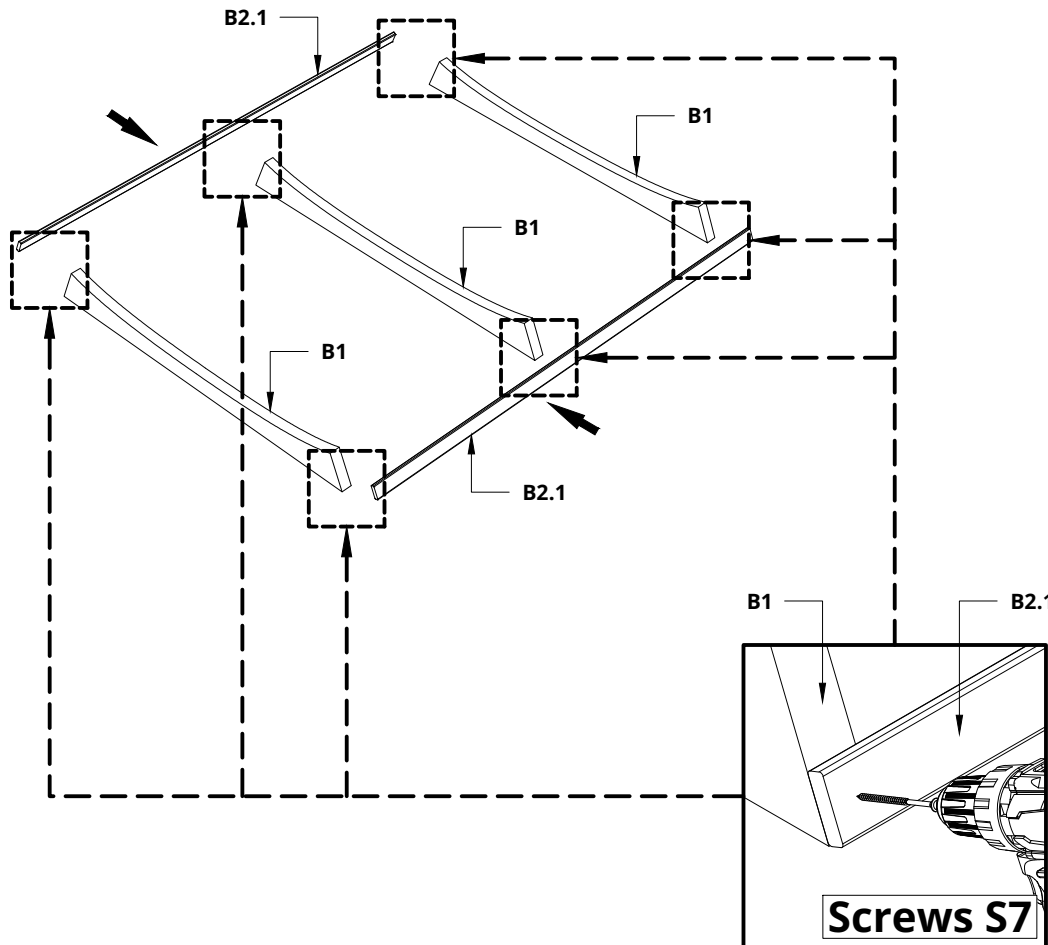

The base of the sauna must be level!

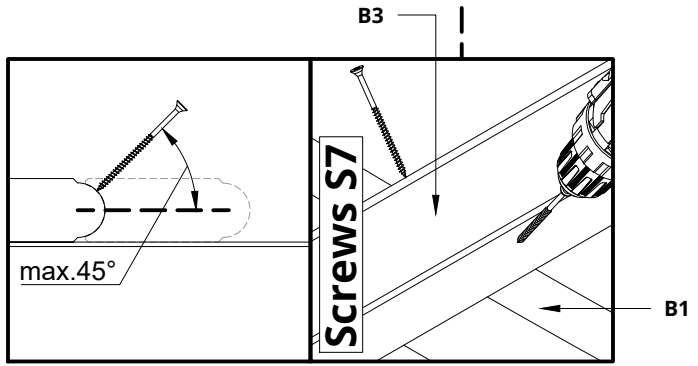
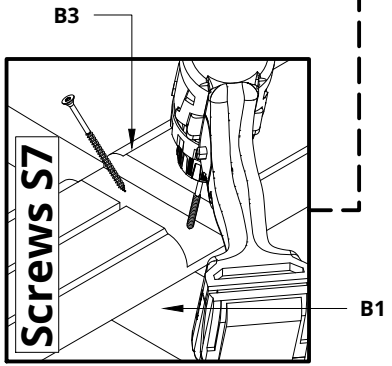
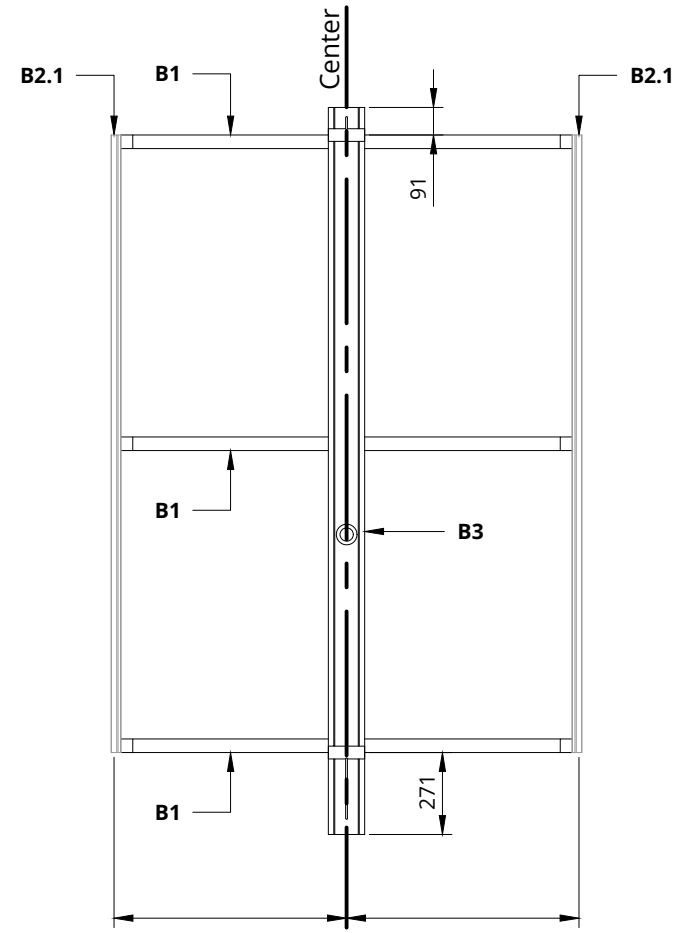
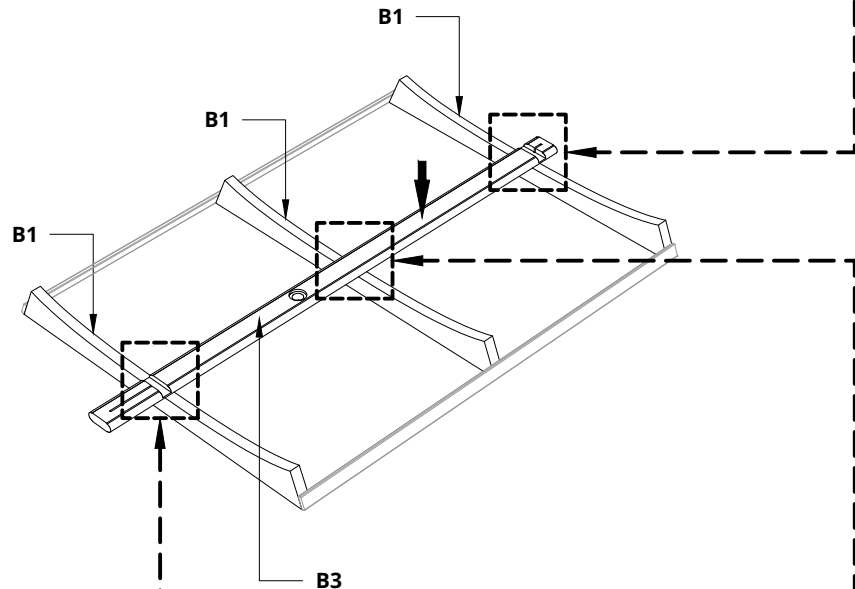
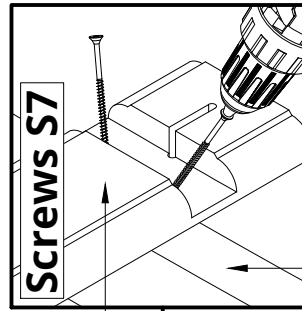

S7	Screws 4,5x80 for Spruce Screws 4,2x75 for Thermo	6
		

Please countersink the screw head(s)!



S7	Screws 4,5x80 for Spruce Screws 4,2x75 for Thermo	36
		

Please countersink the screw head(s)!
Use a rubber mallet to tap the planks together!
Drill 10 mm hole in each plank groove!

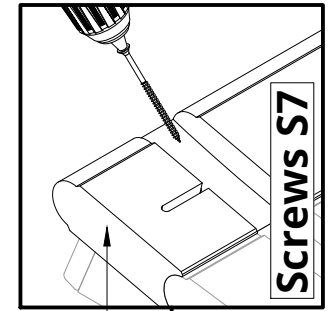
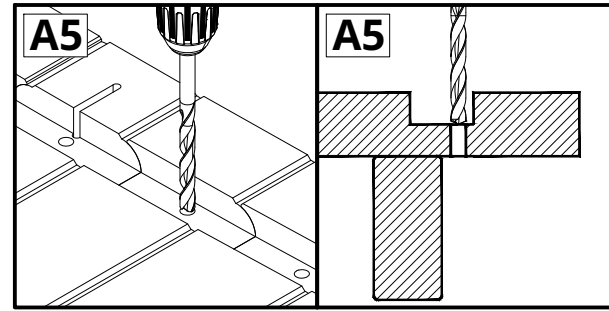
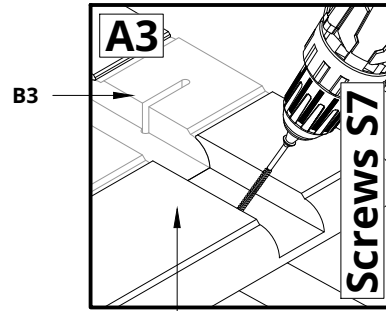

B3a Left and
B3b Right

B3a1 Left and
B3b1 Right

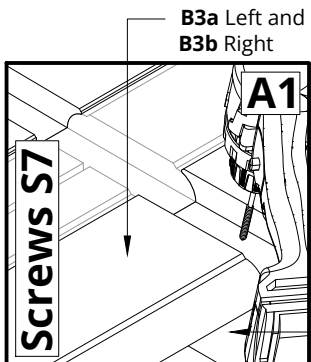
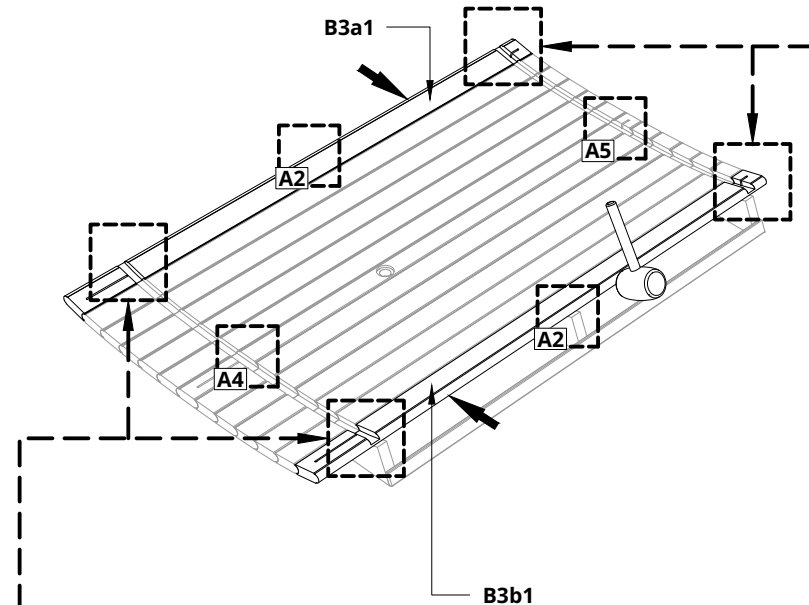
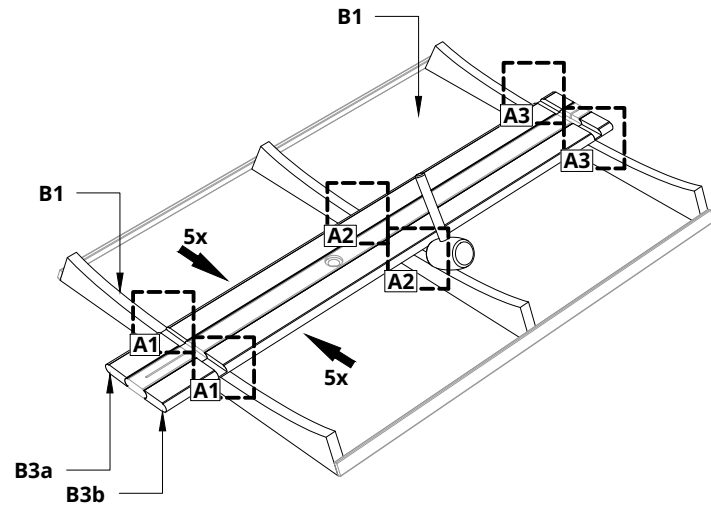

B3a Left and
B3b Right

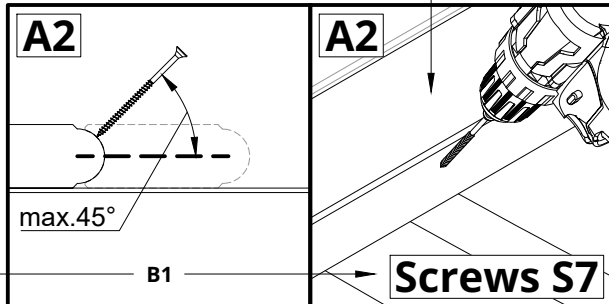

B3a Left and
B3b Right

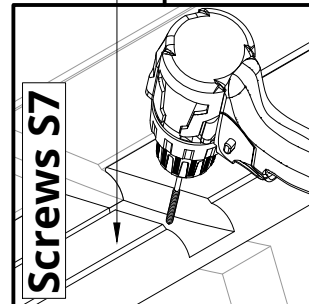

B3a1 Left and
B3b1 Right

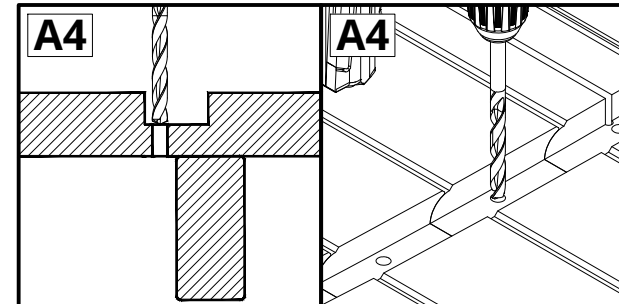

B3b1

**Cut a hole for the drain pipe (only necessary if there is no hole)!
Clean the groove and floor surfaces from wood waste and other dirt!
Cover the grooves and the floor surfaces (middle) with varnish by following the manufacturer's instructions!
Paint the front end and back end of the boards!**

Only necessary if there is no drain pipe hole

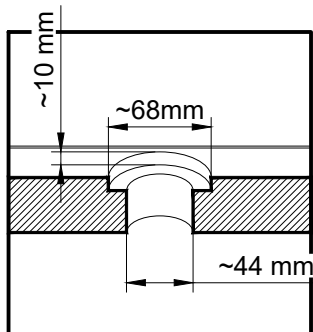
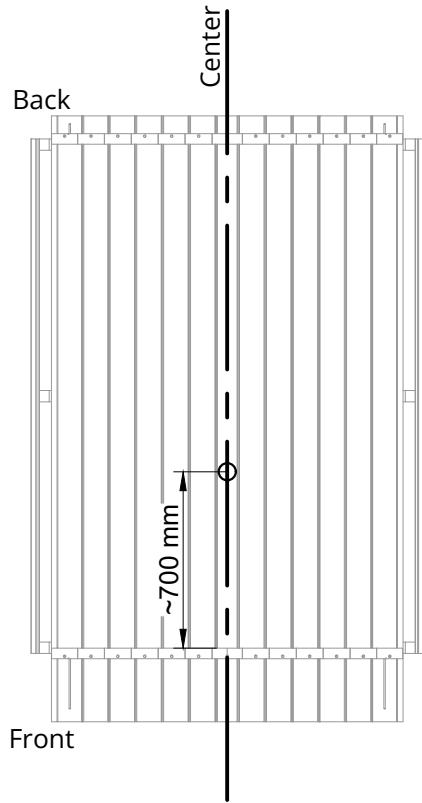

C3
Add two coats of paint
(Remmer HK lasur PINE)

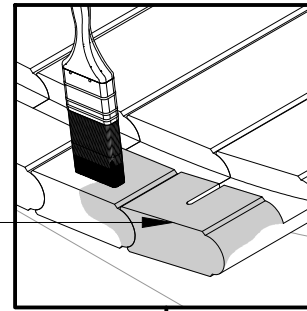

C1
Add two coats
of varnish
(INARIJÄRVI)

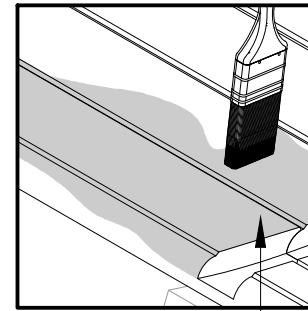
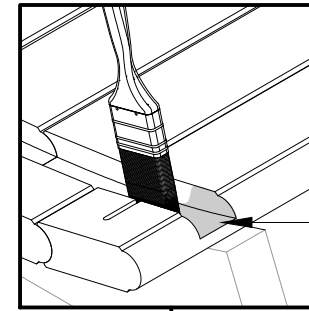

C2
Add two or three
coats of varnish
(HELO AQUA 40)

(HELO AQUA 40 IS FOR THE FLOOR ONLY)

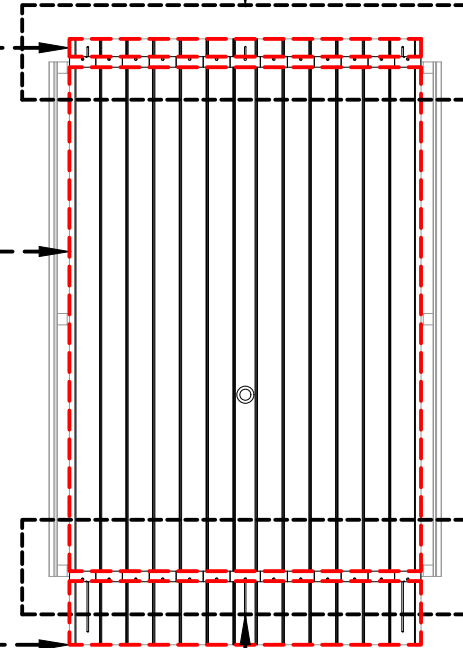

C3
Add two coats of paint
(Remmer HK lasur PINE)

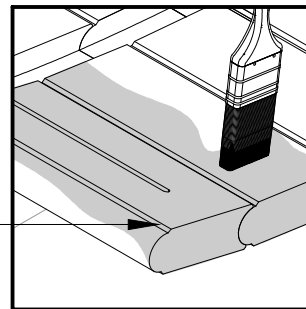

C1
Add two coats
of varnish
(INARIJÄRVI)

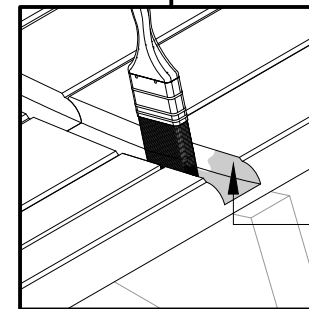

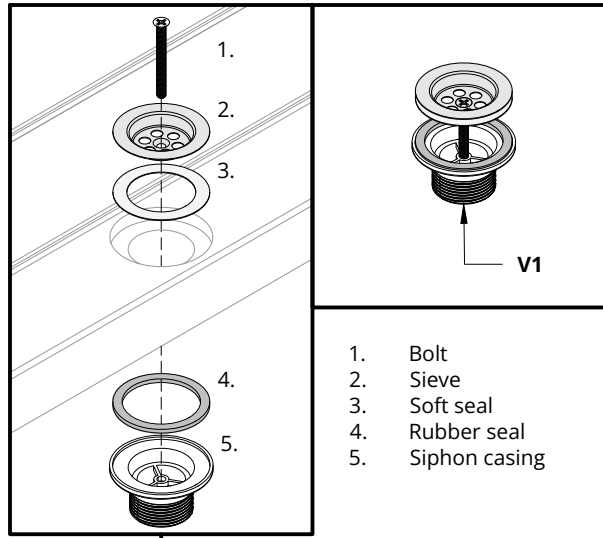

S7	Screws 4,5x80 for Spruce Screws 4,2x75 for Thermo	2
		

Lift the bottom of the sauna up on one side and install some aids!
Clean the bottom surface!
Cover the surface with paint (black), let the paint dry!
Install a piece of drain pipe V1!
Install the rubber seal R1!
Remove boards B2.1!

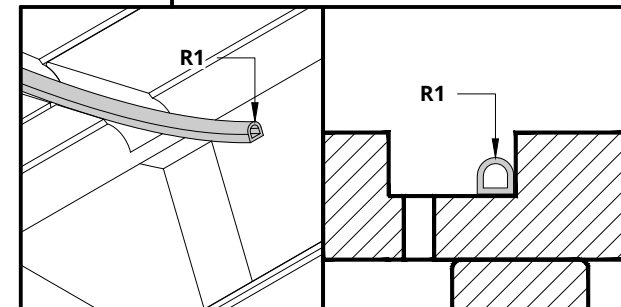
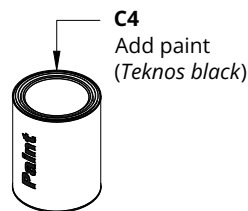
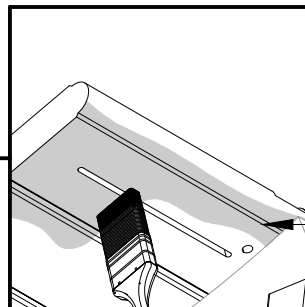
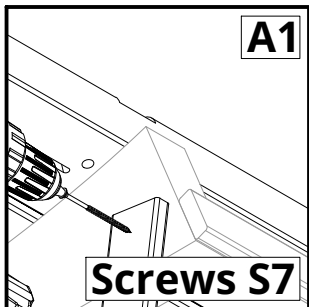
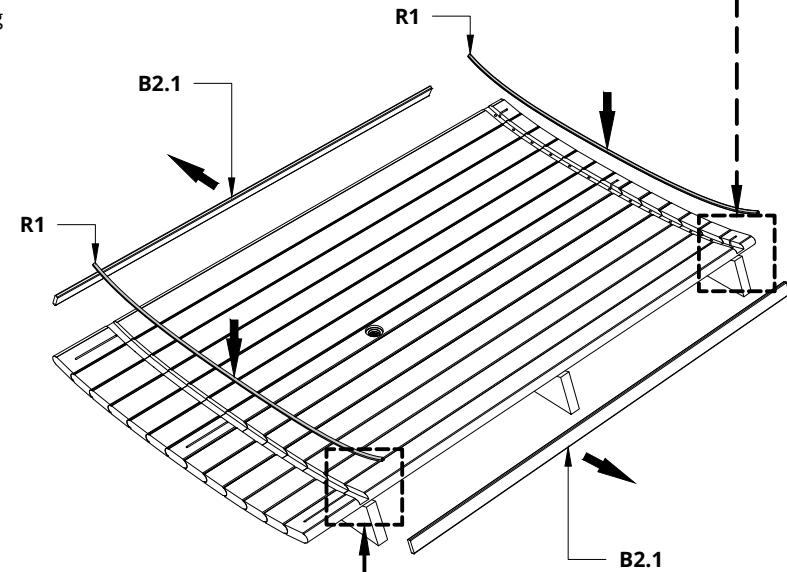
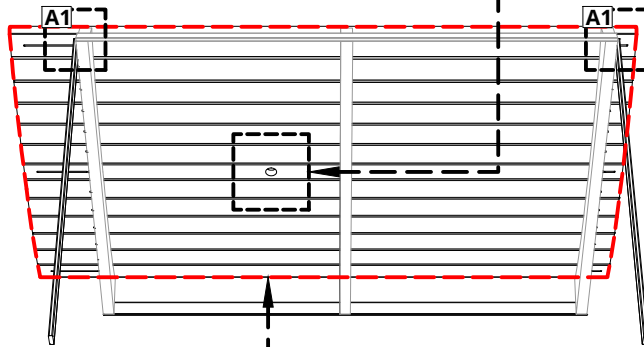
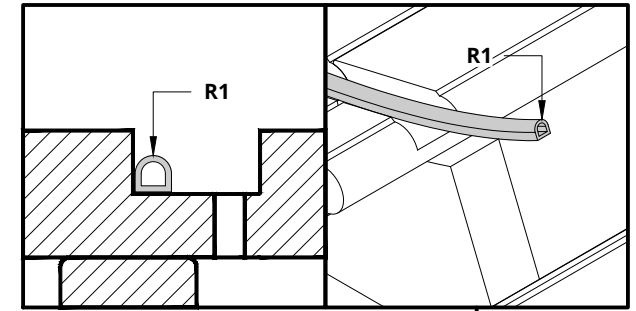

1. Bolt
2. Sieve
3. Soft seal
4. Rubber seal
5. Siphon casing



S5	Screws 4,5x60 for Spruce Screws 4,2x55 for Thermo	12
		

Please countersink the screw head(s)!
Assemble and prepare of the front wall!
Remove the door moldings (B7a)!
Use glue between the B4a and B4b!
Fasten the parts with screws and jigs!
Let the glue dry according to the glue manufacturer's recommendations!
Clean the edge of the wall from wood waste and other dirt!
Varnish the edge of the wall from the bottom to middle by following the manufacturer's instructions!

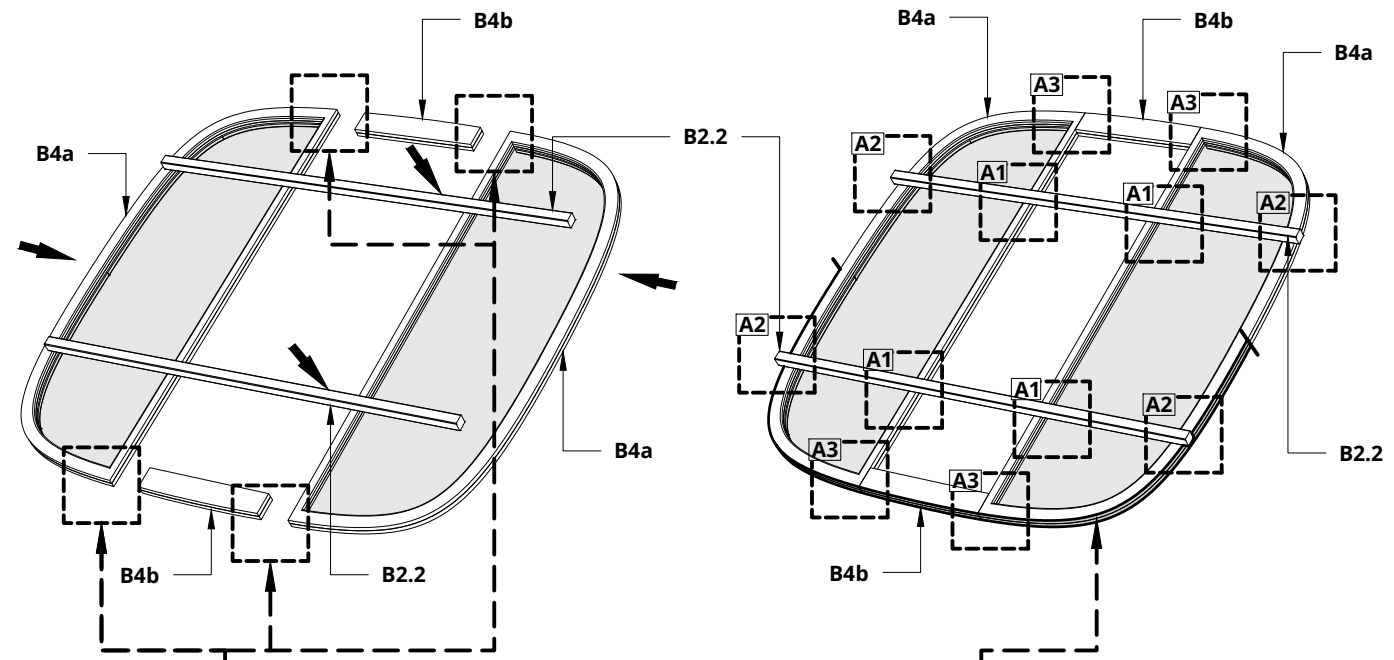
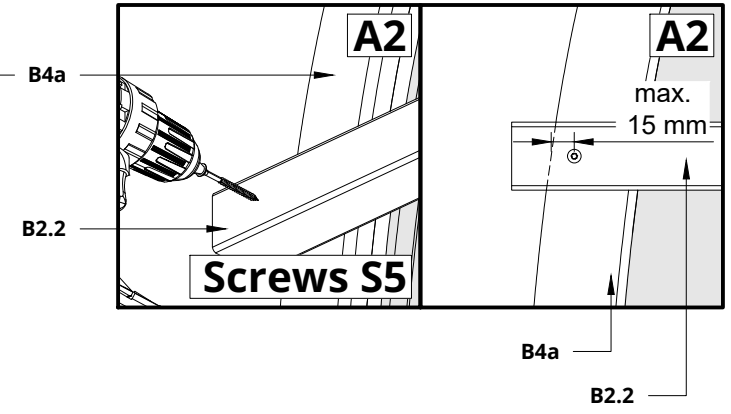
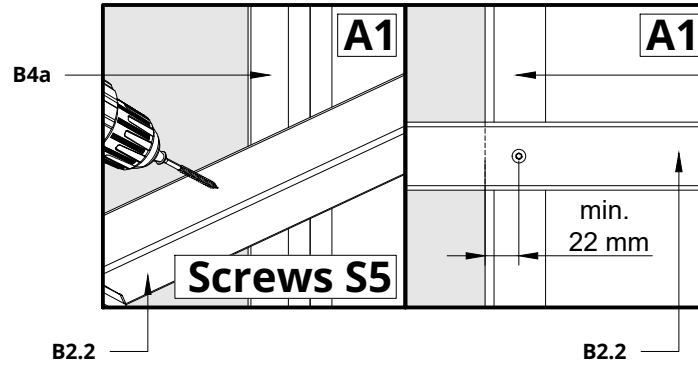

Remove the door molding (B7a) from both B4a. Fixed with 5 screws.

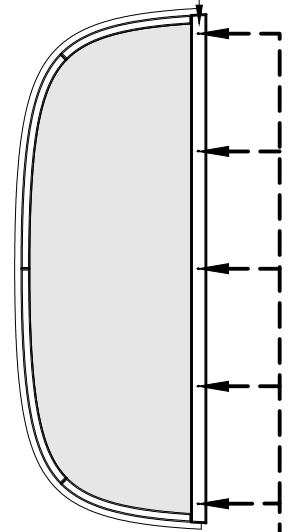

Remove the door molding (B7a) from both B4a Fixed with 5 screws

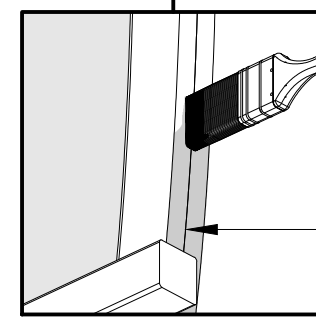
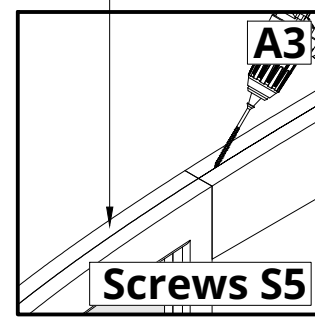
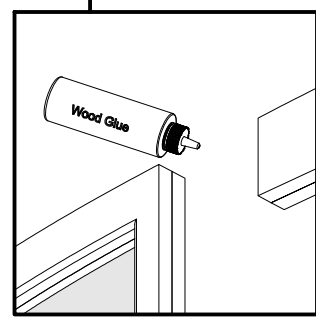
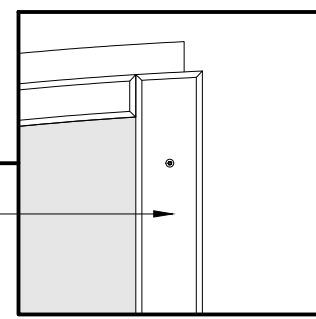

C1 Add two coats of varnish (INARIJÄRVI)



Prepare the lower and upper part of the back wall!

Clean the edge of the lower part of the back wall and the outer surface from wood waste and other dirt!

Varnish the edge of the lower part of the back wall from the bottom to middle by following the manufacturer's instructions!

Cover the lower part and upper part of the back wall outer surface with paint, let the paint dry!

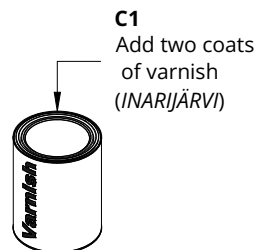
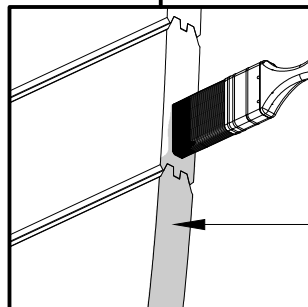
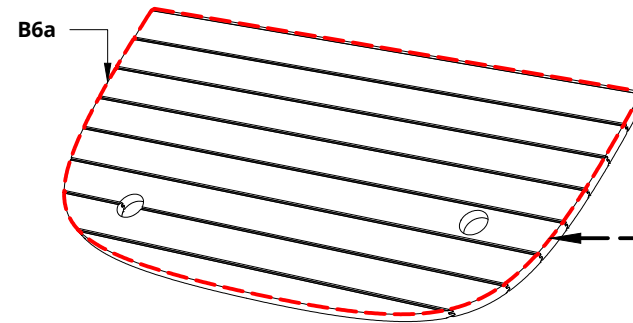
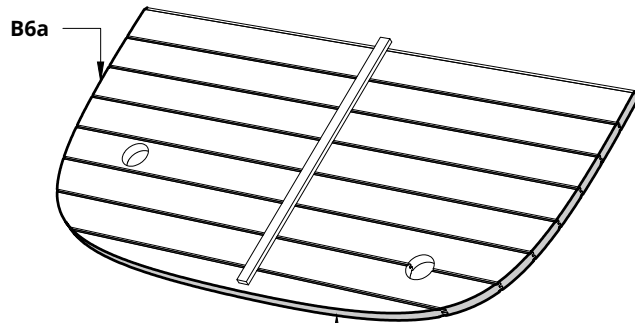
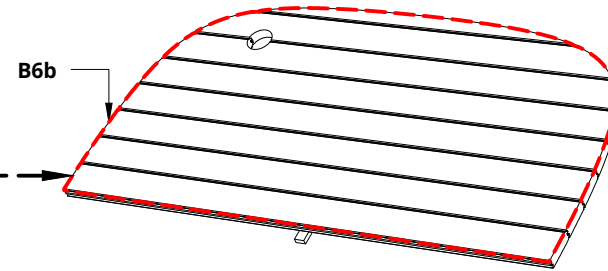
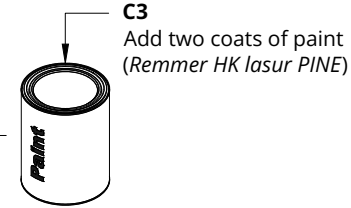
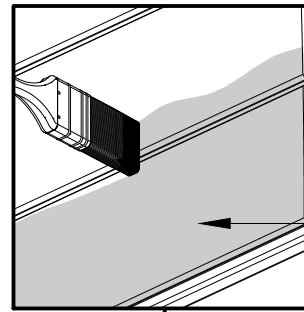

C3
Add two coats of paint
(Remmer HK lasur PINE)

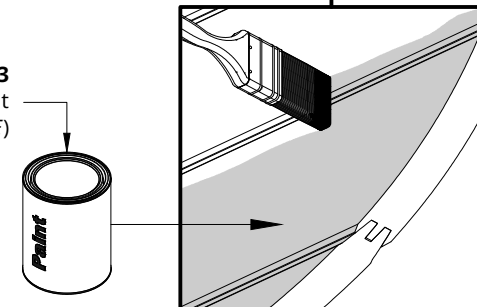

Preparation for side wall boards.

Before doing the processes, clean the sidewall boards from wood waste and other dirt!

Boards	First ones		The following ones					
	B3a	B3b	B3a	B3b	B3a	B3b	B3a	B3b
Process 1	✓	✓	✗	✗	✗	✗	✗	✗
Process 2	✓	✓	✓	✓	✓	✓	✓	✓
Process 3	✓	✓	✓	✓	✓	✓	✗	✗
Label them	1L	1R	2L	2R	3L	3R	4L	4R
Quantity	2	2	3	3	6	6	21	21

C4
Add paint
(Teknos black)

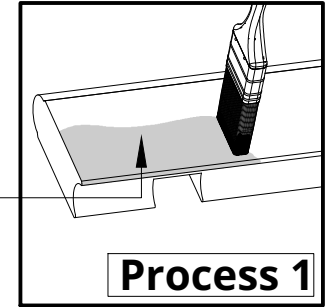

Process 1

C3
Add two coats of paint
(Remmer HK lasur PINE)

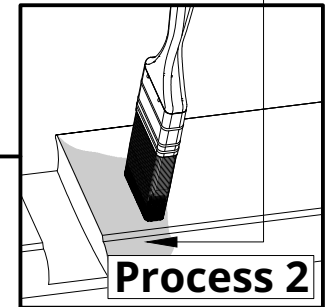

Process 2

C1
Add two coats
of varnish
(INARIJÄRVI)

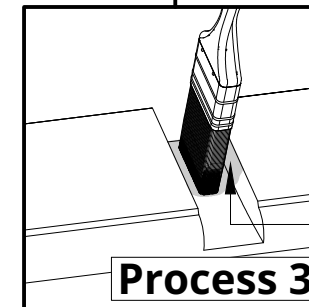

Process 3

C1
Add two coats
of varnish
(INARIJÄRVI)

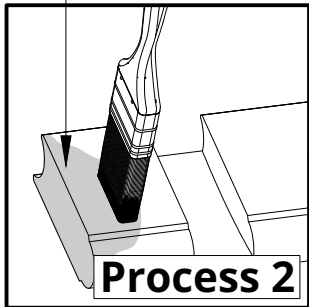

Process 2

C3
Add two coats of paint
(Remmer HK lasur PINE)

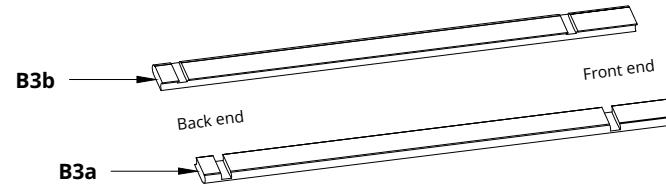

Side without grooves





Back end

Front end

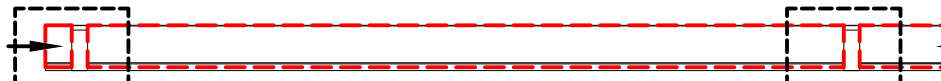

Side of the board with front and back wall grooves



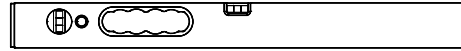

S5	Screws 4,5x60 for Spruce Screws 4,2x55 for Thermo	4
		

NB! use a level

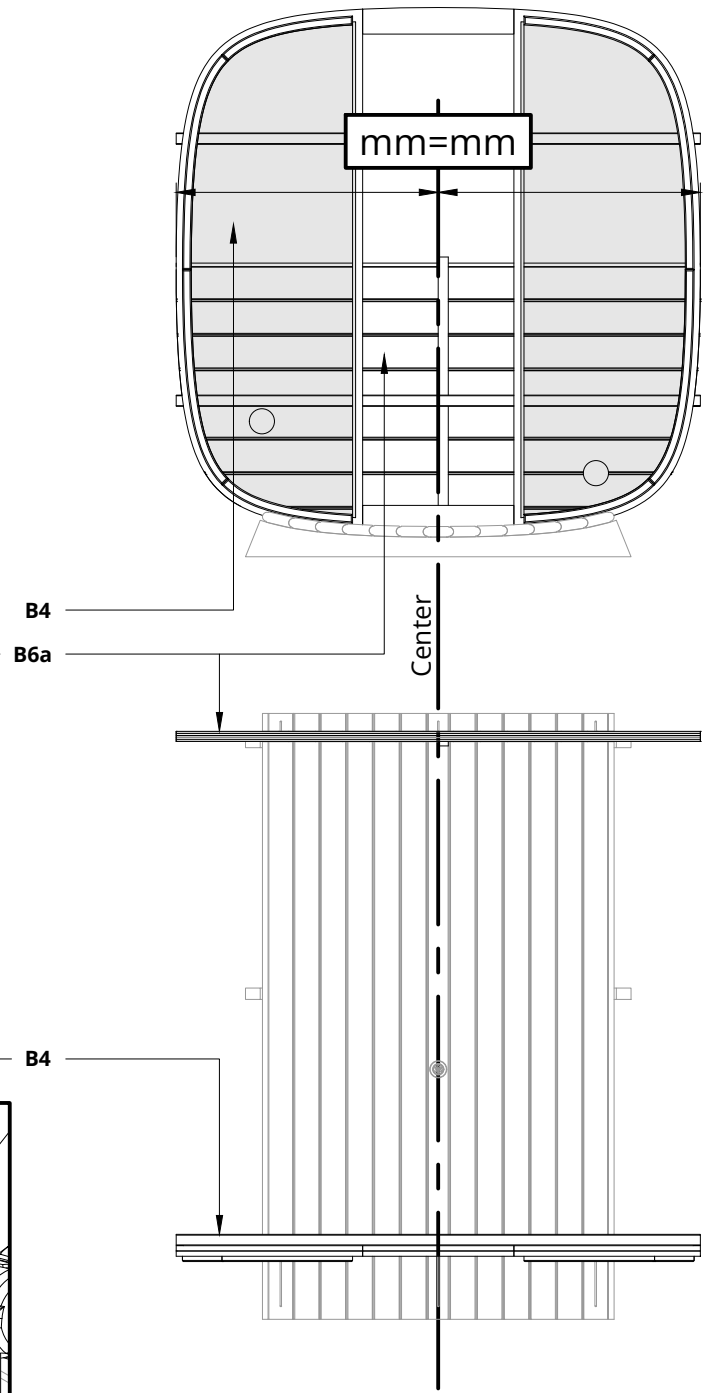
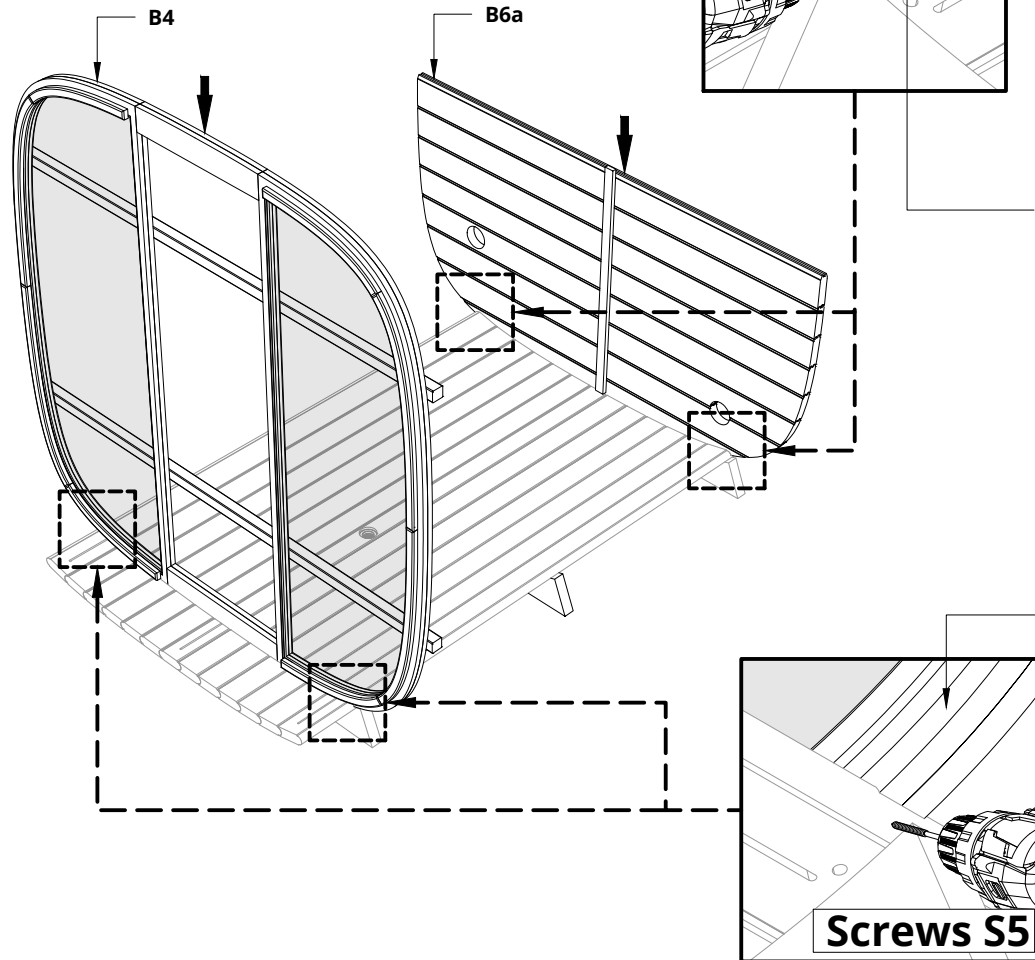

Please countersink the screw head(s)!
Make sure that the front wall and the lower part of the back wall are centered in relation to the bottom!
Install the front wall and the lower part of the back wall B6a!



S7	Screws 4,5x80 for Spruce Screws 4,2x75 for Thermo	2
S5	Screws 4,5x60 for Spruce Screws 4,2x55 for Thermo	8
		

Please countersink the screw head(s)!
Use boards B3a and B3b, that are labeled as 4L and 4R!
First install the lower safety boards on walls!
Install the upper part of the back wall B6b and the upper safety board!
Remove the back wall connection strips!

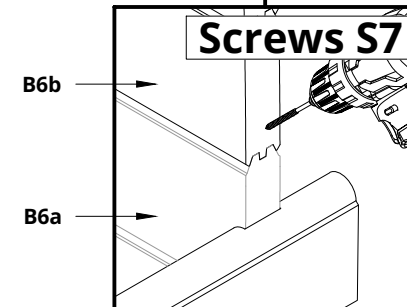
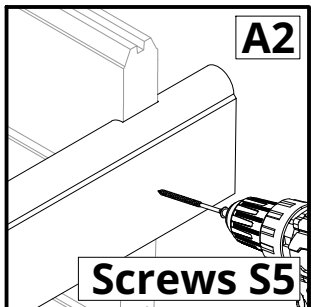
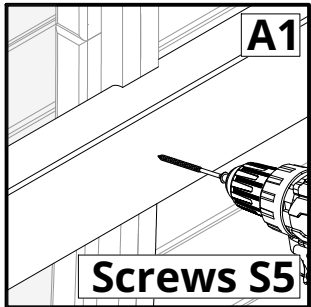
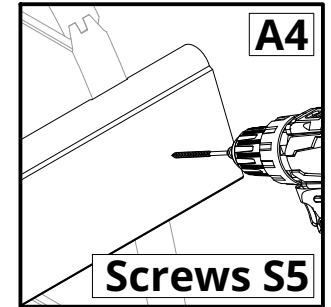
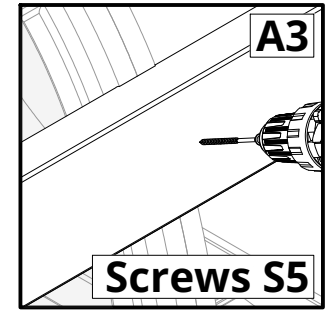
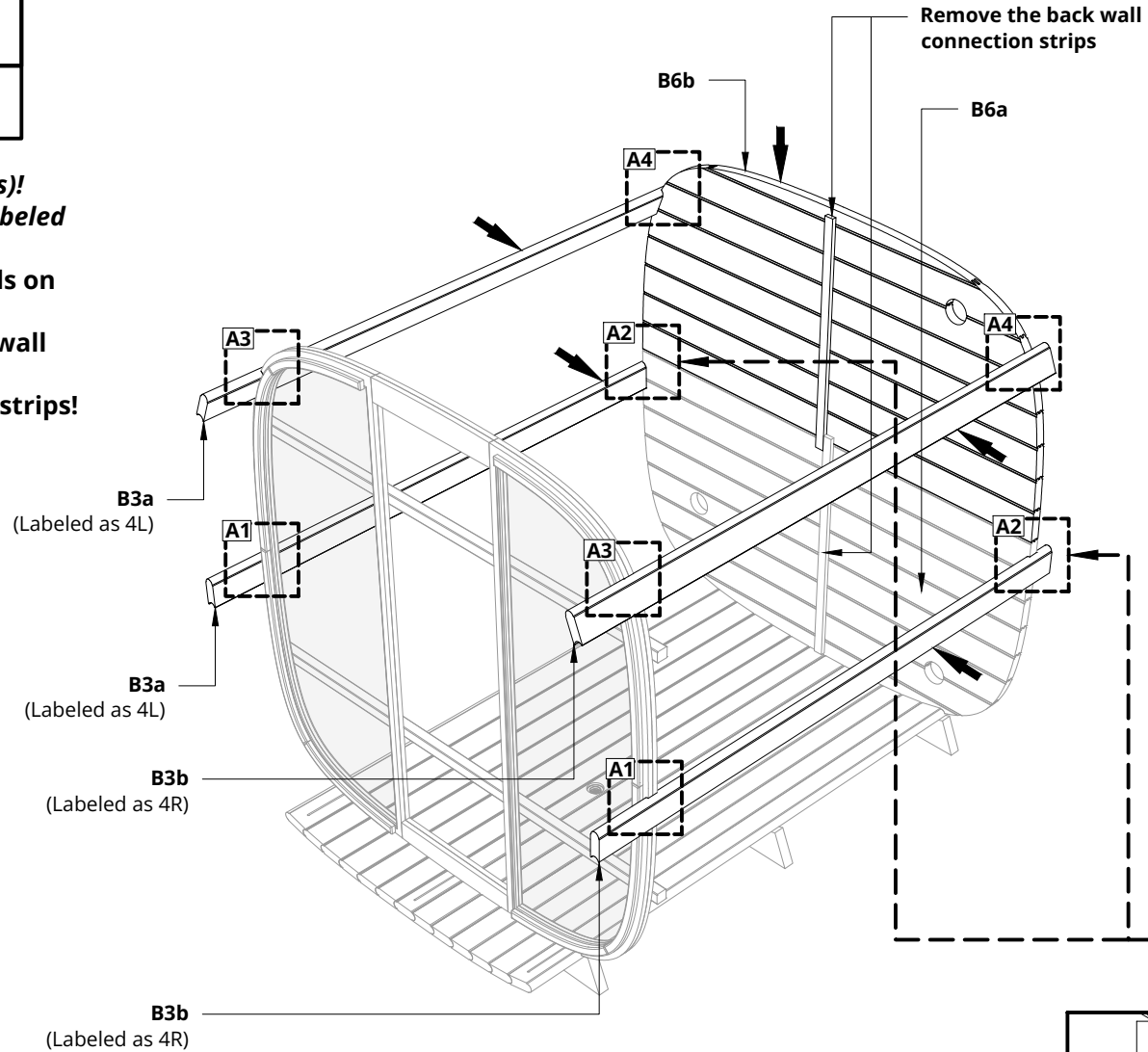

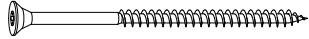
S5	Screws 4,5x60 for Spruce Screws 4,2x55 for Thermo	104
		

Please countersink the screw head(s)!
Use a rubber mallet to tap the planks into place!
Please do not screw the screws in on the last whole blanks immediately!

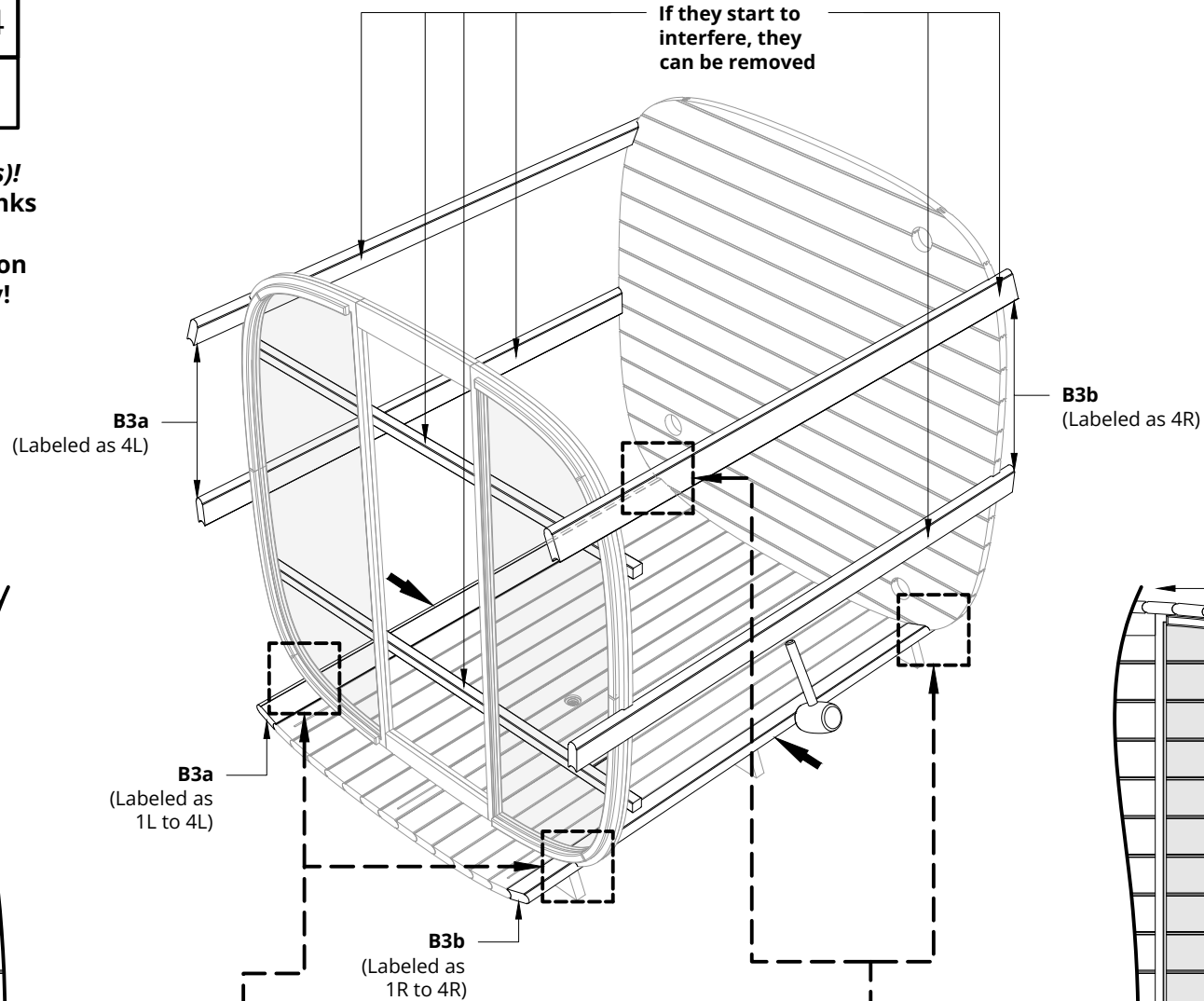
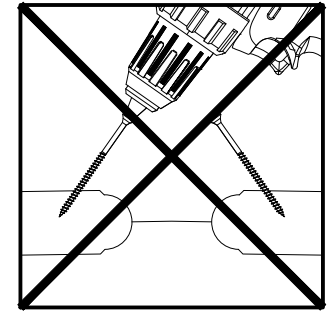

B3a
layout of labeled boards

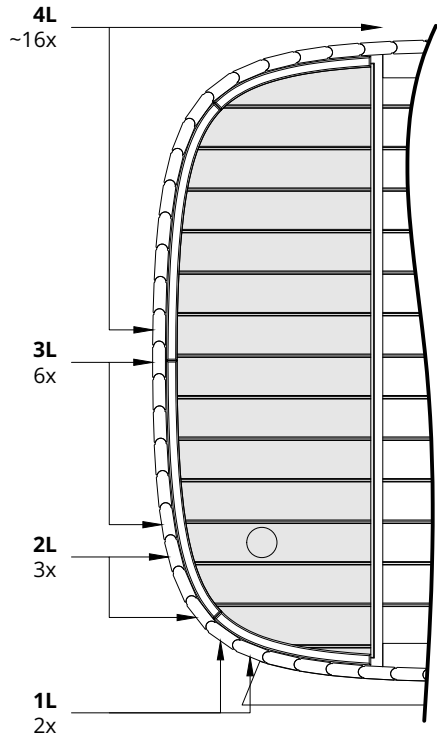

B3b
layout of labeled boards

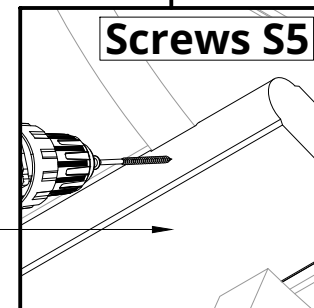
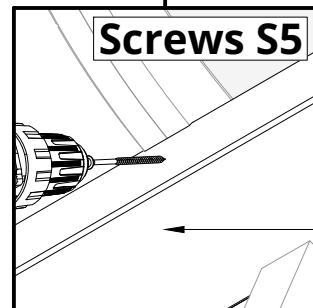
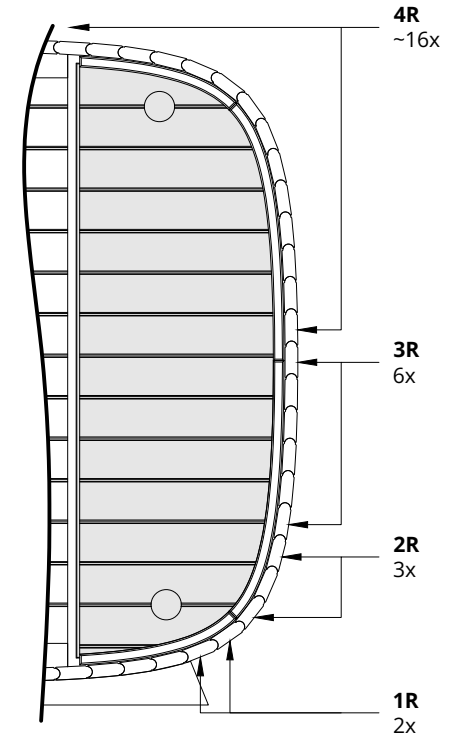

B3a left
 (Labeled as 1L to 4L)
B3b right
 (Labeled as 1R to 4R)

Measure the gap front and back, the dimensions can be different!

Divide the measurement by two and transfer the measurements to the last two planks. Connect the dimensions on the plank with a line.

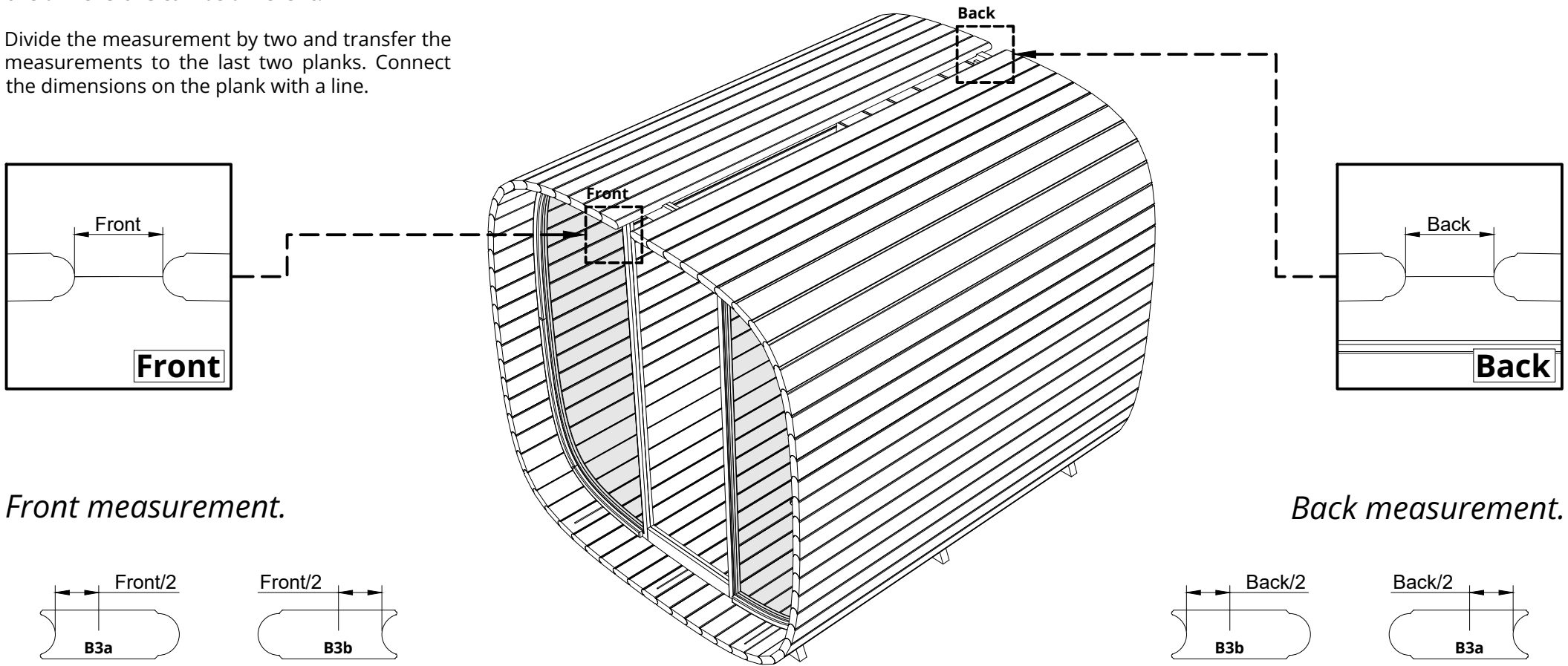

Front measurement.

Back measurement.

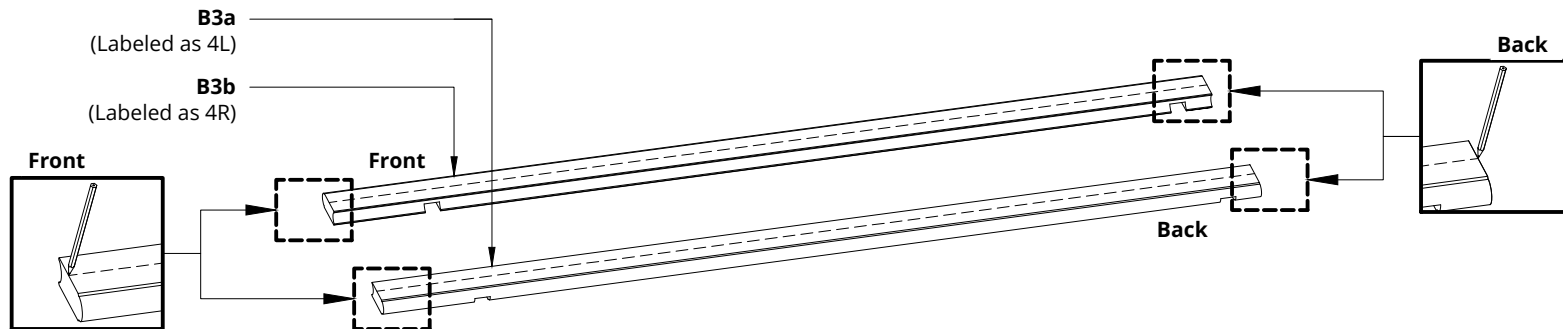

S2...7	Screws 3x40 ... 4,5x80	9
S5	Screws 4,5x60 for Spruce Screws 4,2x55 for Thermo	6
		

Please countersink the screw head(s)!
Prepare the last plank!
Use a rubber mallet to tap the planks in to the cap!

Cut along the marked line to cut off these ends. Glue the two cut boards with wood glue and connect them with 9 pieces of 3x40 ... 4.5x80 screws (the length of the screws depends on the final width of the last two planks cut). Wipe off excess glue with a cloth and then use sandpaper to smooth out the gap.

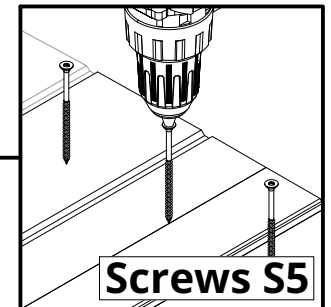
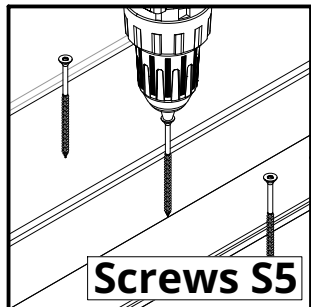
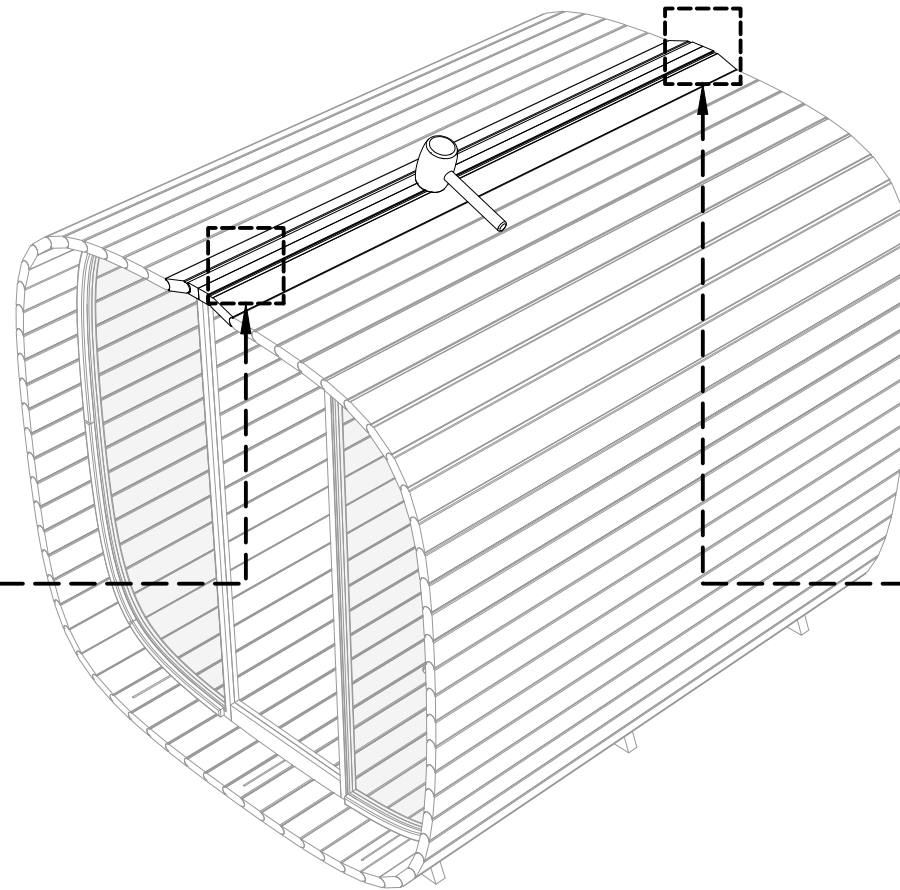
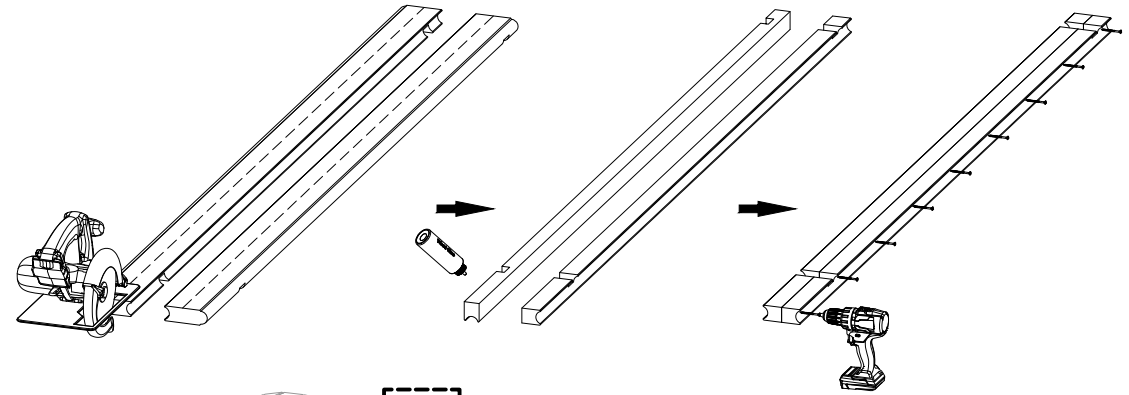

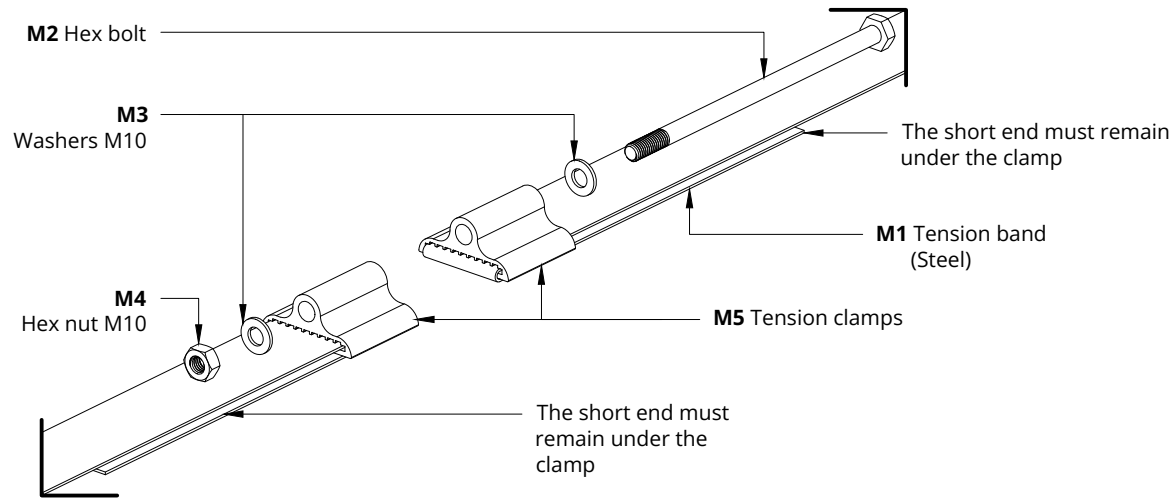



Place the tension bands M1 (Steel band) around the side walls and thread the bands into the eyelet as follows (see sketch above).

Hex nuts and bolts must be tightened as long as the planks are stationary in all directions.

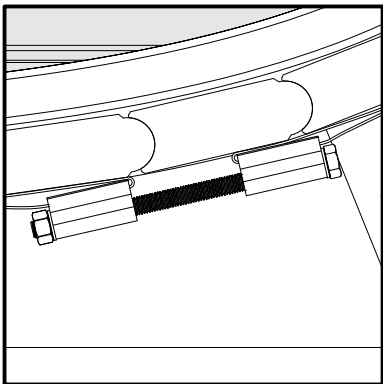
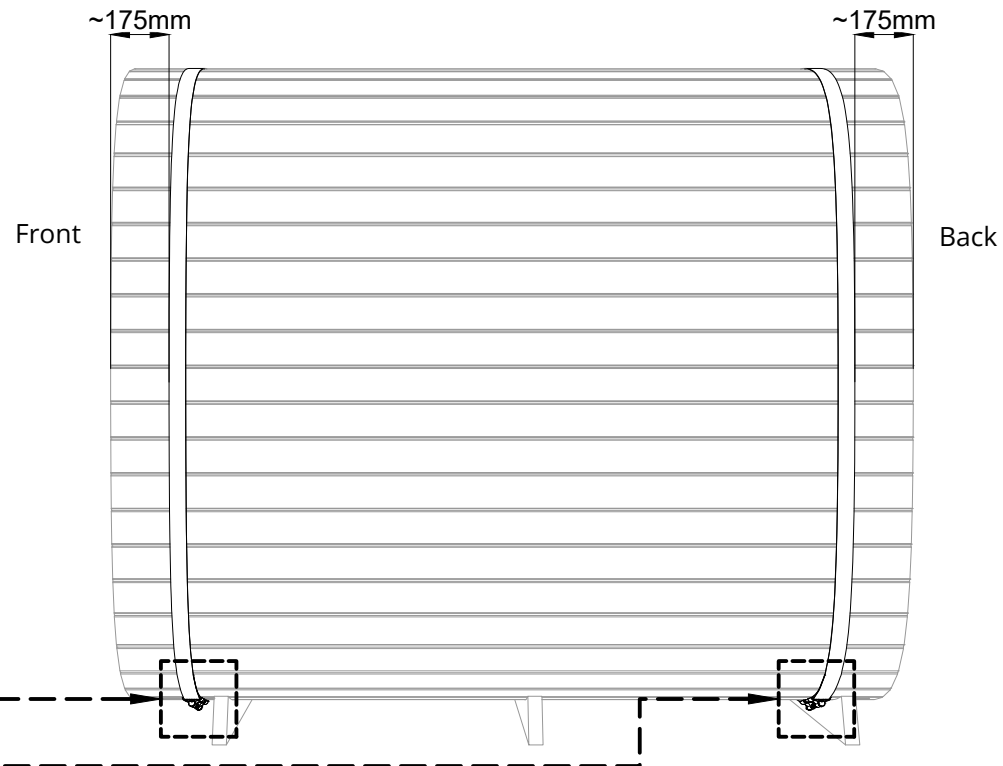
The tension band and clamps must be placed as shown in the picture below.



R5	Nail 2,5x20...25	~40
		

Install the underlay in the center of the roof!
The underlay must extend over the front end and back end!
Fasten the underlay along the long edges!
Use a heat source when bending the underlays front end and back end!
Fasten the underlay front end and back end!
Cut off the ends that extend over the edge!

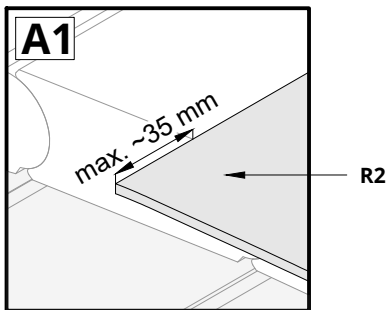
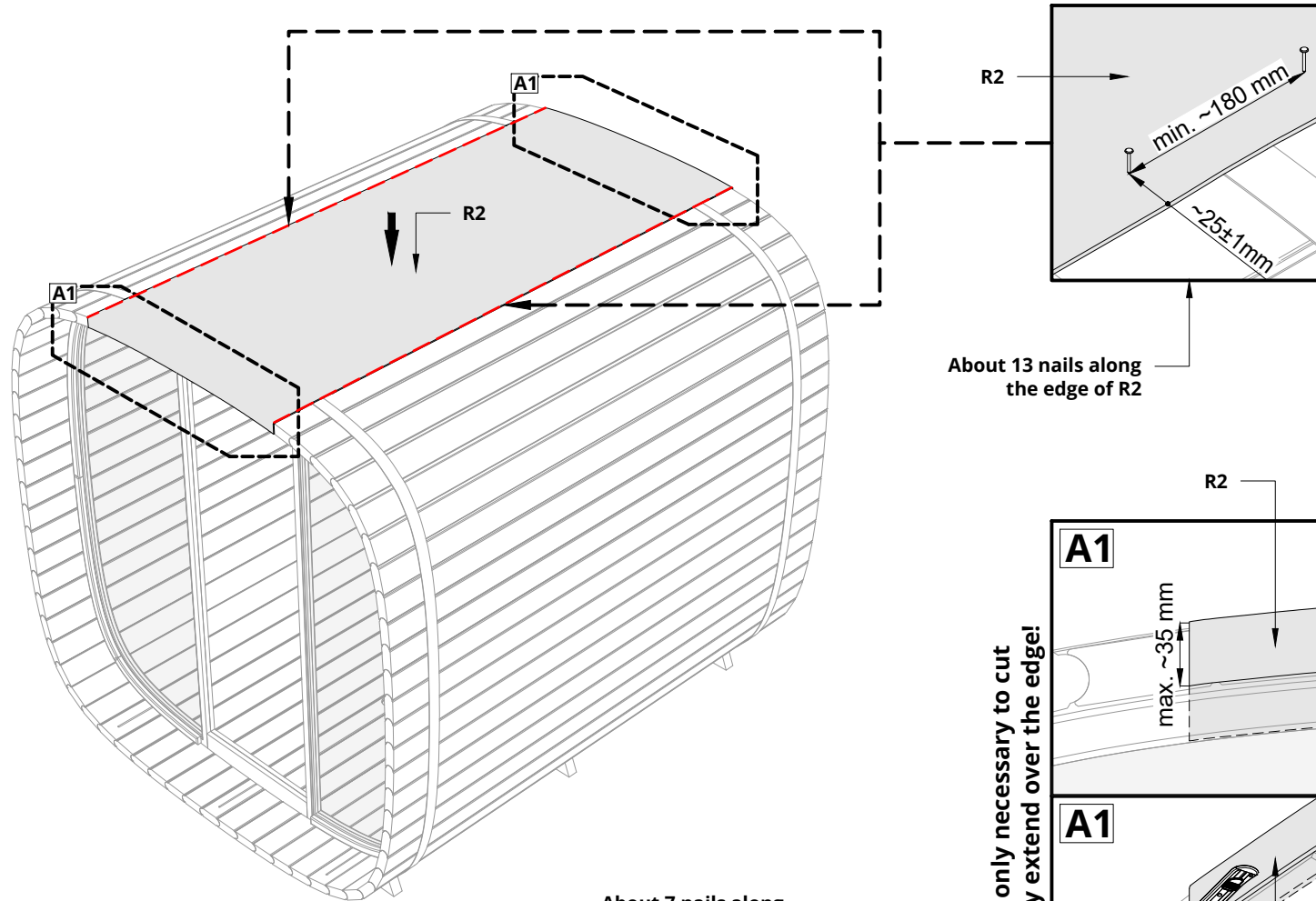

Use a heat source when bending the underlays

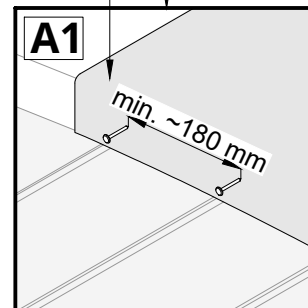
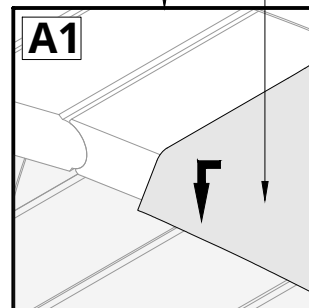
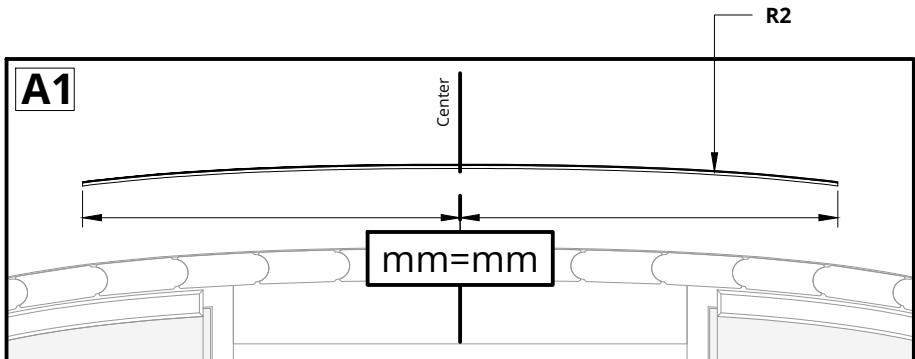

It is only necessary to cut if they extend over the edge!

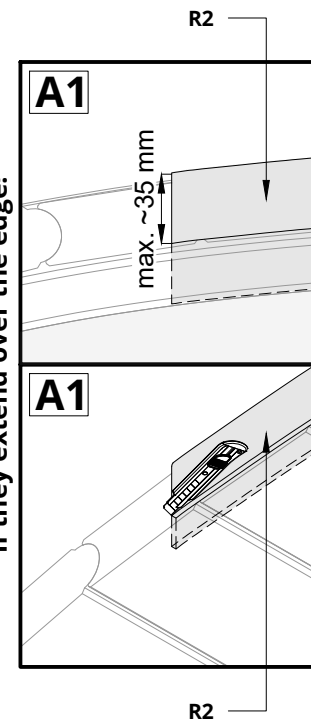

Katepal 3T Rectangle bitumen roof sheet row arrangement for Round Cube saunas.

The base row is installed first, then the first row, etc. up in the middle of the sauna. The sheets that remain over the edge of the sauna wall are cut off and, if possible, used for other rows.

The base row starts at the front end and offset from the front end of the sauna, row 1 always starts in the middle.

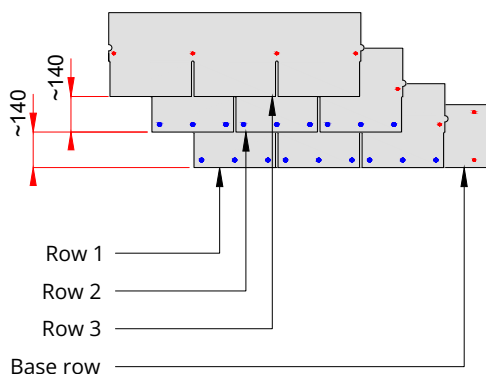
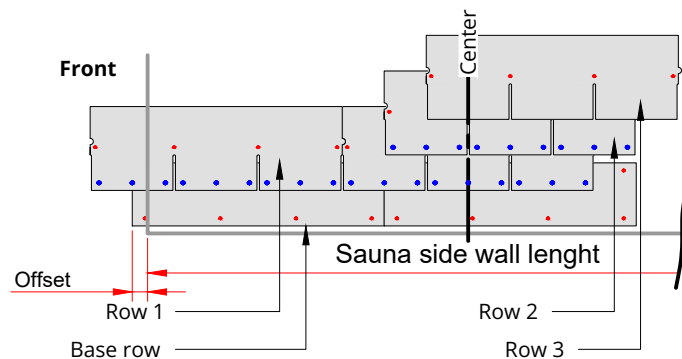

- **R7** - Sheet metal screw 4,2x25
(Black coated screw head) **Only first two rows!!!**
- **R6** - Nail 2,5x20...25

Katepal 3T Rectangle Bitumen roof sheet cutting and fastening.

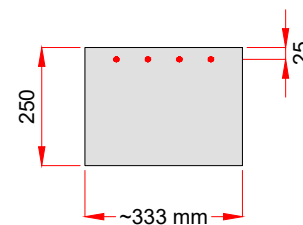
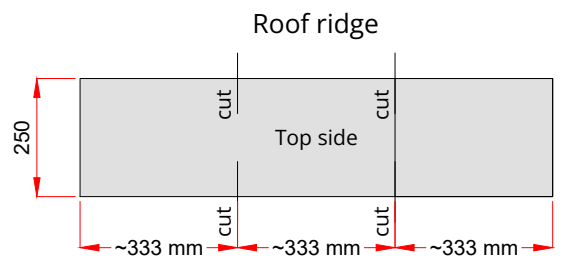
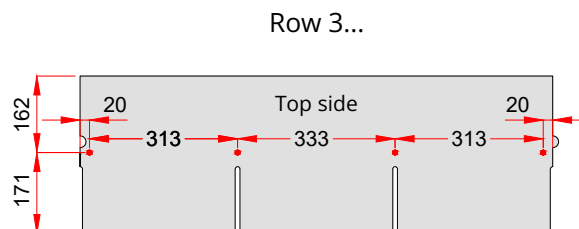
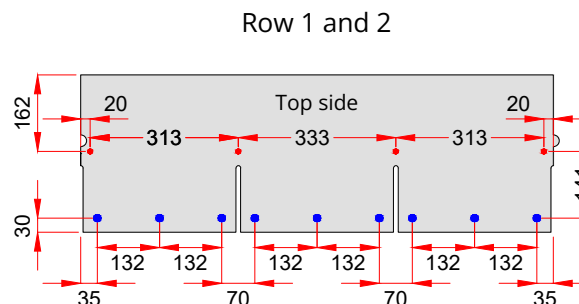
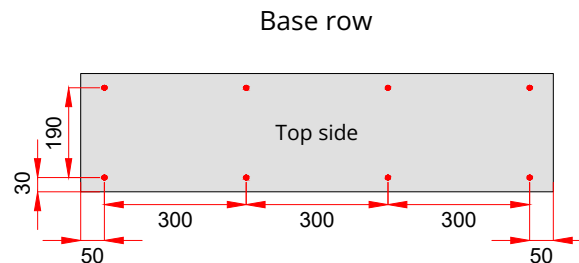

Roof ridge installation.

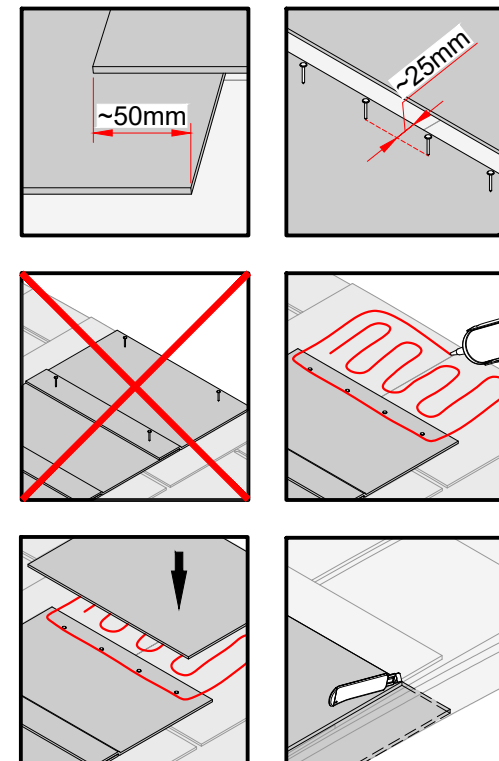

Katepal 3T Rectangle

bitumen roof sheet row arrangement for
Round cube length - 2.4m

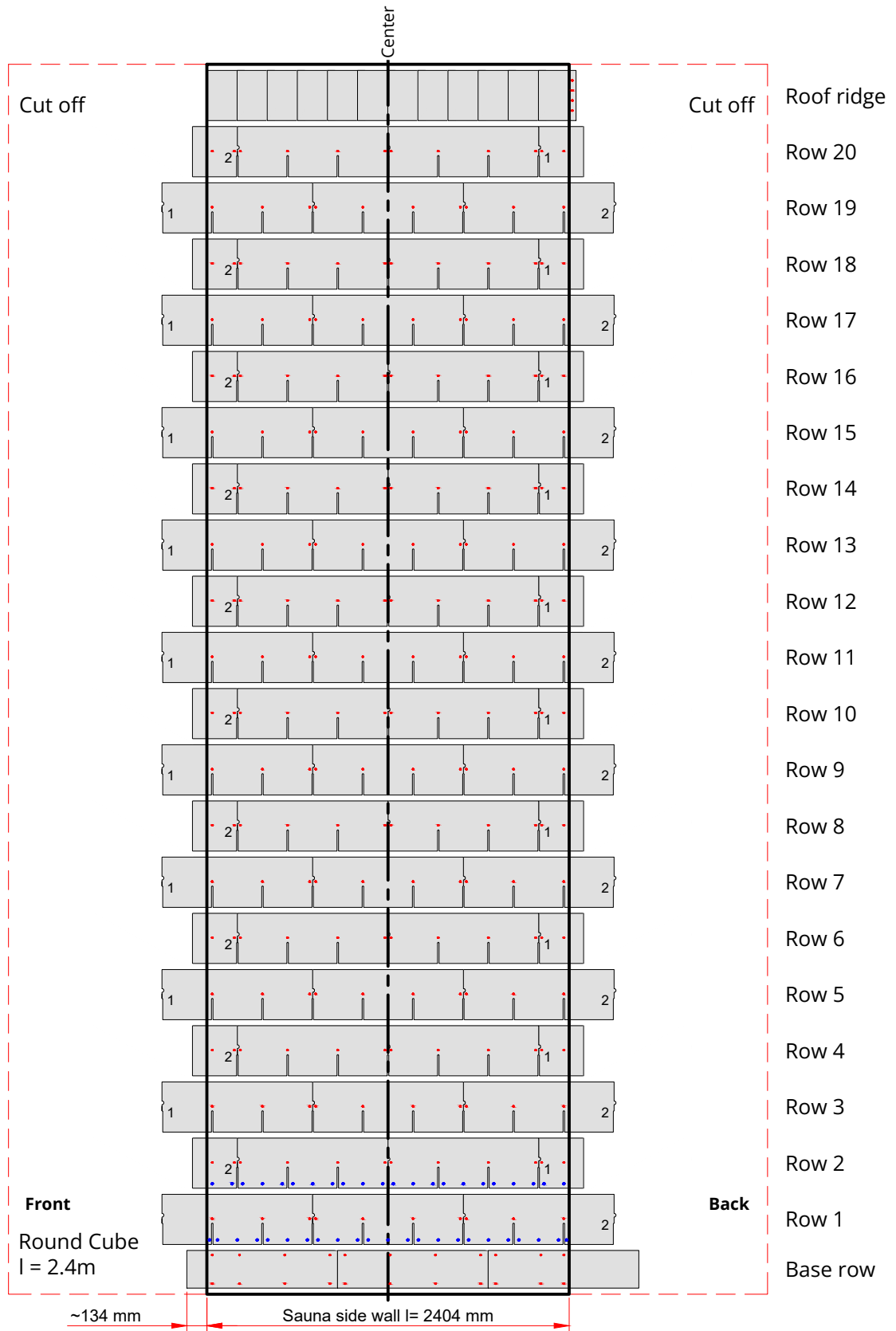
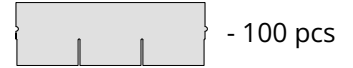

- **R7** - Sheet metal screw 4,2x25
(Black coated screw head) **Only first two rows!!!**
- **R6** - Nail 2,5x20...25

Rec. (MINI 2.4)

R5	Nail 2,5x20...25	~42
		

Sheets are self-adhesive, for better adhesion use a heat source!

The base row starts from the front, from the second board and with offset!

Cut sheets that extend over the edge! (It is only necessary to cut if they extend over the edge!)

Suitable leftovers can be used!

Repeat these steps on the other side as well!

See recommendation for proper installation!

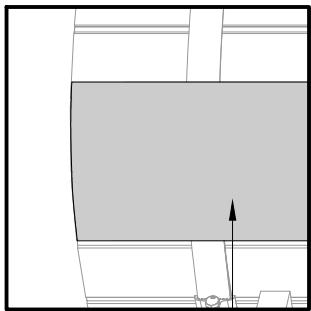

R3

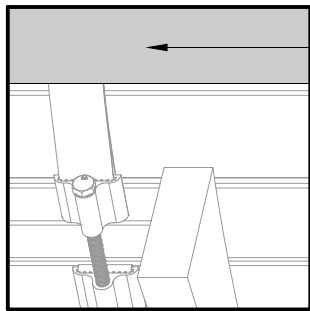

R3

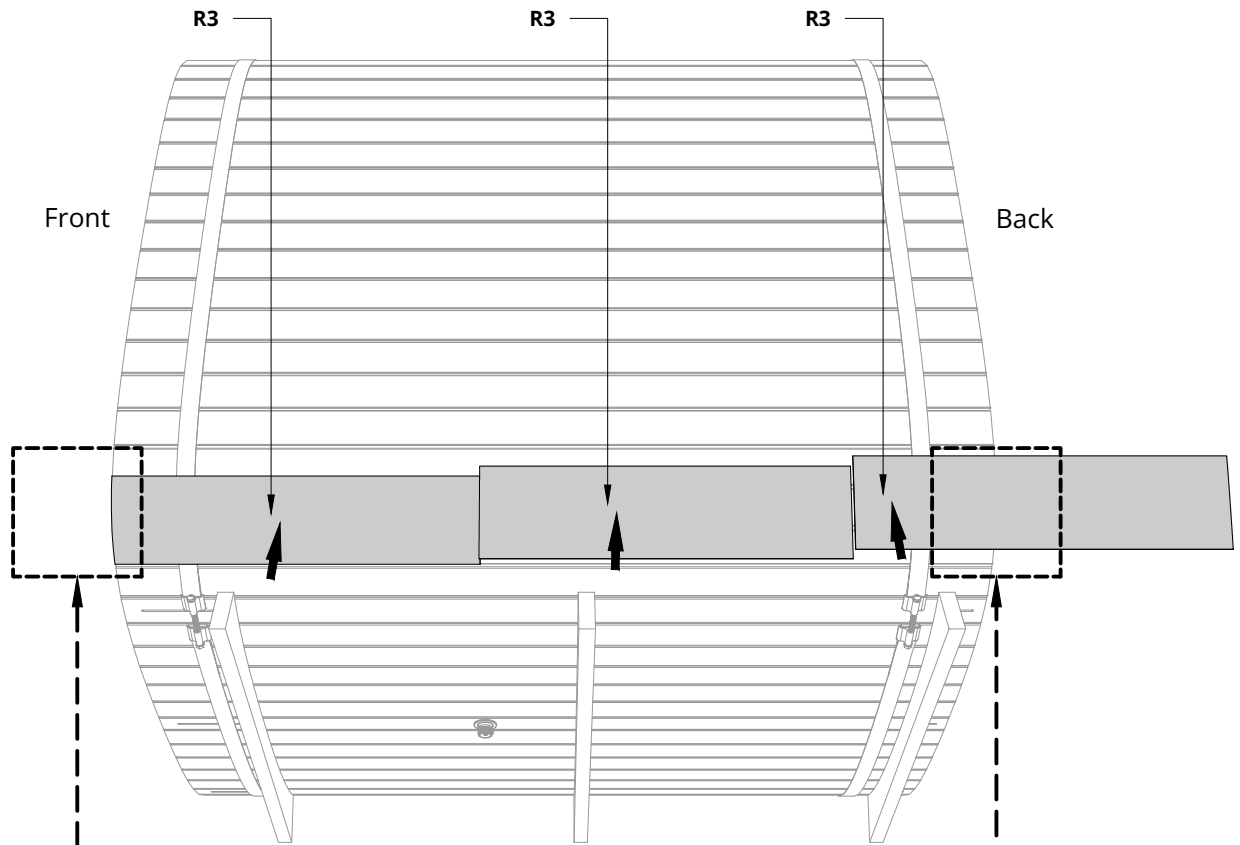
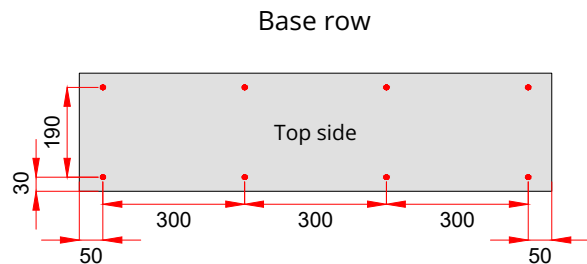

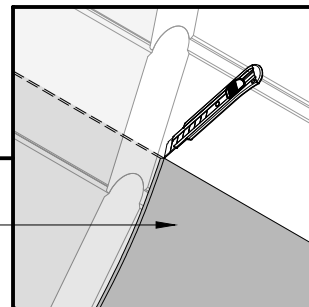

It is only necessary to cut if they extend over the edge!

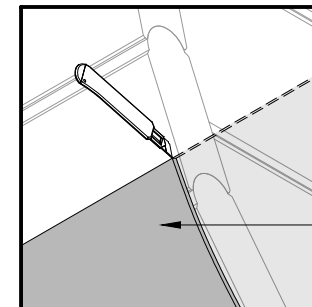

R3



R3

R5	Nail 2,5x20...25	~482
		
R7	(Black coated screw head) Sheet metal screw 4,2x25	~90
		

Sheets are self-adhesive, for better adhesion use a heat source!
The 1.row starts from the bottom and center of the side wall of the sauna.
Cut sheets that extend over the edge!
Suitable leftovers can be used!
Repeat these steps on the other side as well!

See recommendation for proper installation!

- R7 - Sheet metal screw 4,2x25
(Black coated screw head)
- R6 - Nail 2,5x20...25

Row 1 and 2

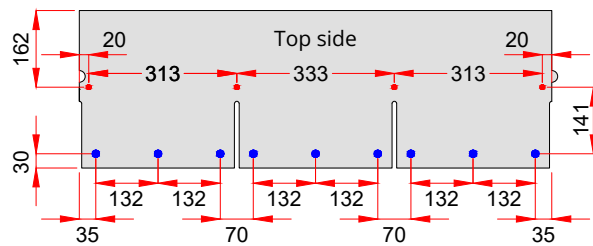

Row 3...

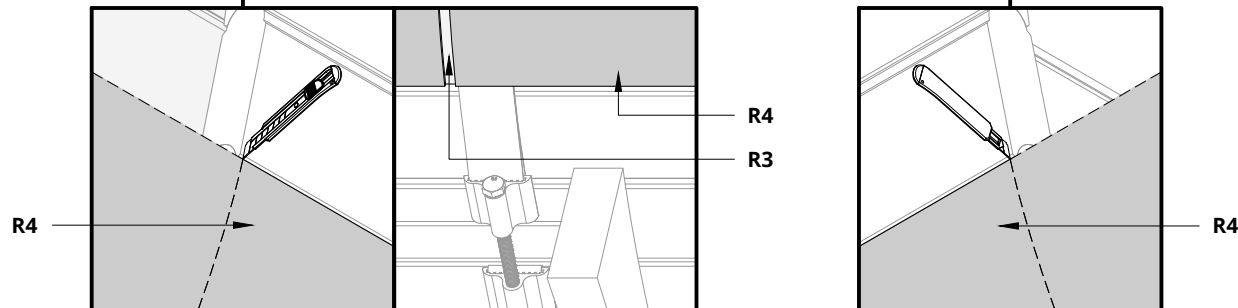
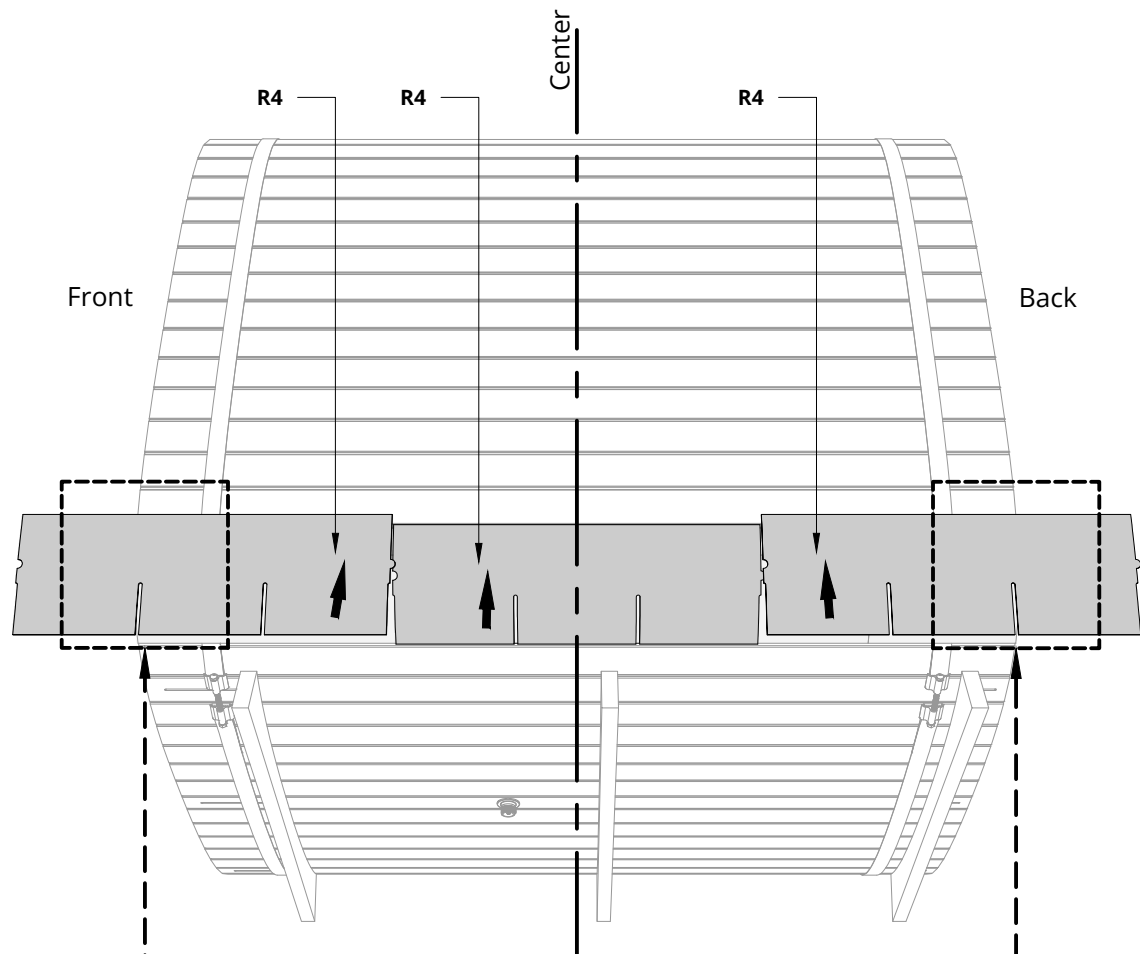
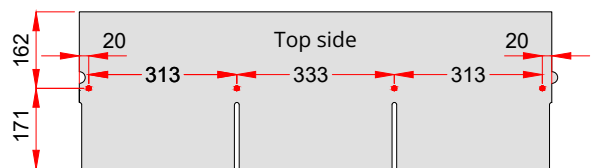

R5	Nail 2,5x20...25	~50
		

Sheets are self-adhesive, for better adhesion use a heat source!
 The roof ridge can be started from the back end of the sauna or from the front end!
 Cut sheets that extend over the edge!

See recommendation for proper installation!

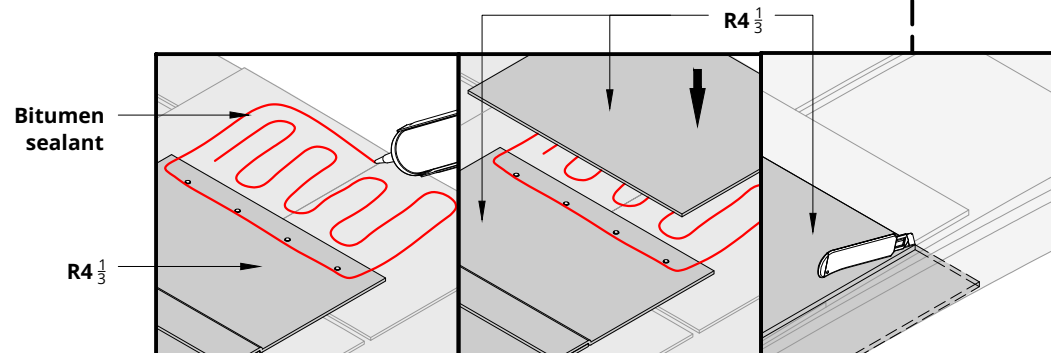
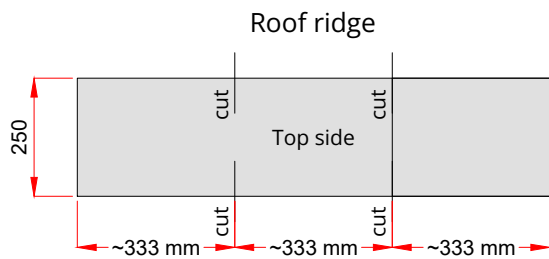
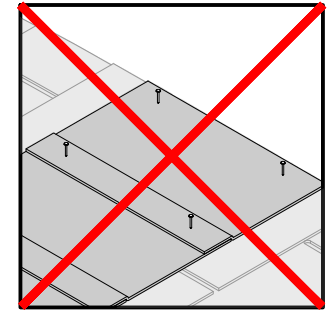
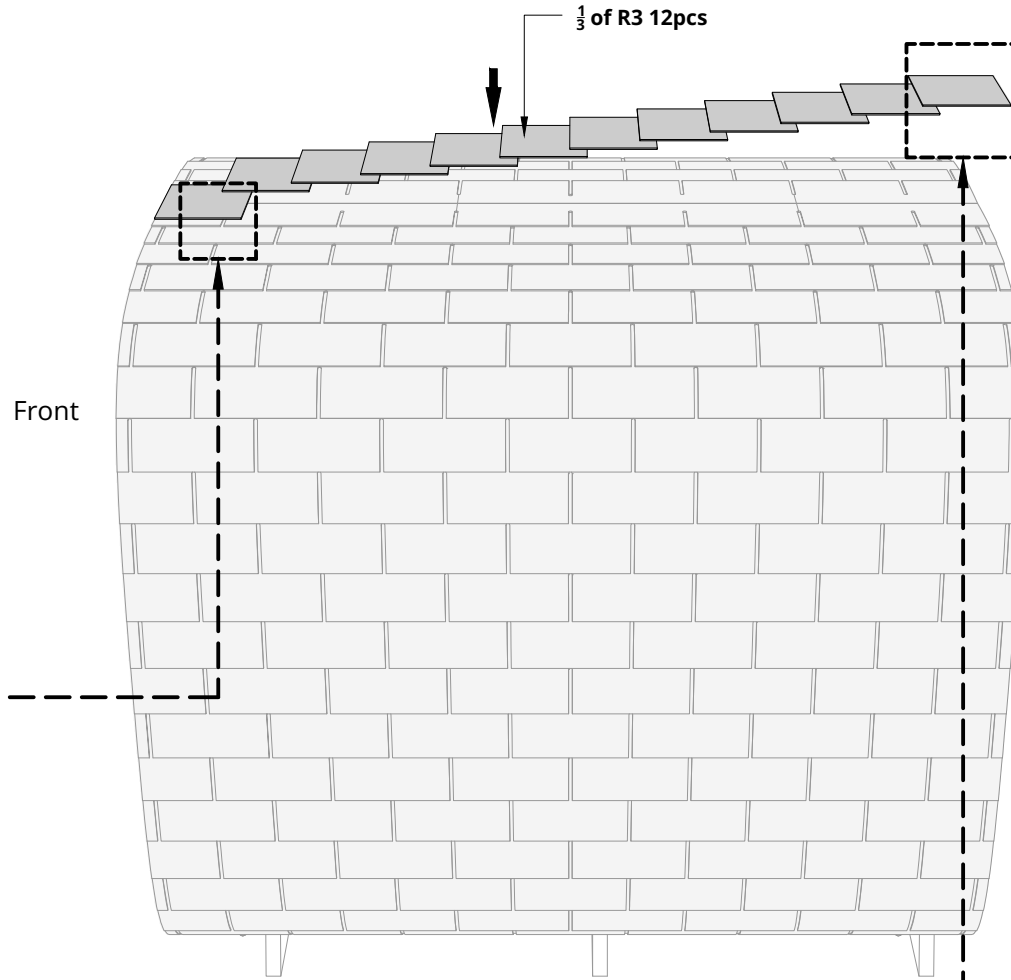
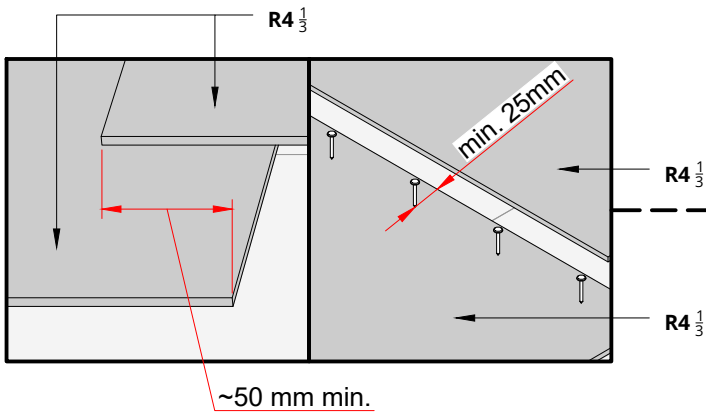

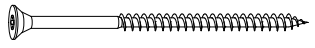
S6.1	Screws 4,5x70 (Black coated)	48
		

Please countersink the screw head(s)!
Install the cover boards with 3 screws!
Add glue for the 2 lower cover boards!
Fill the gaps between the bitumen sheets and covering boards in front and back!

NB! use a level

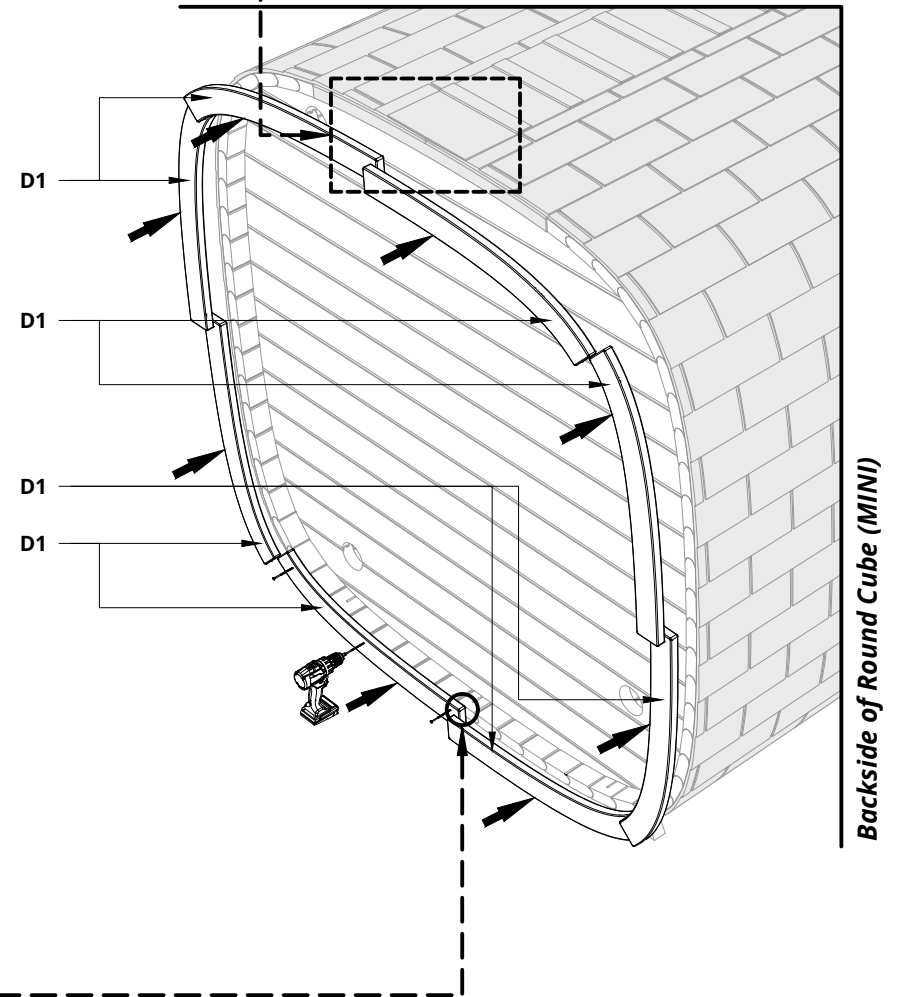
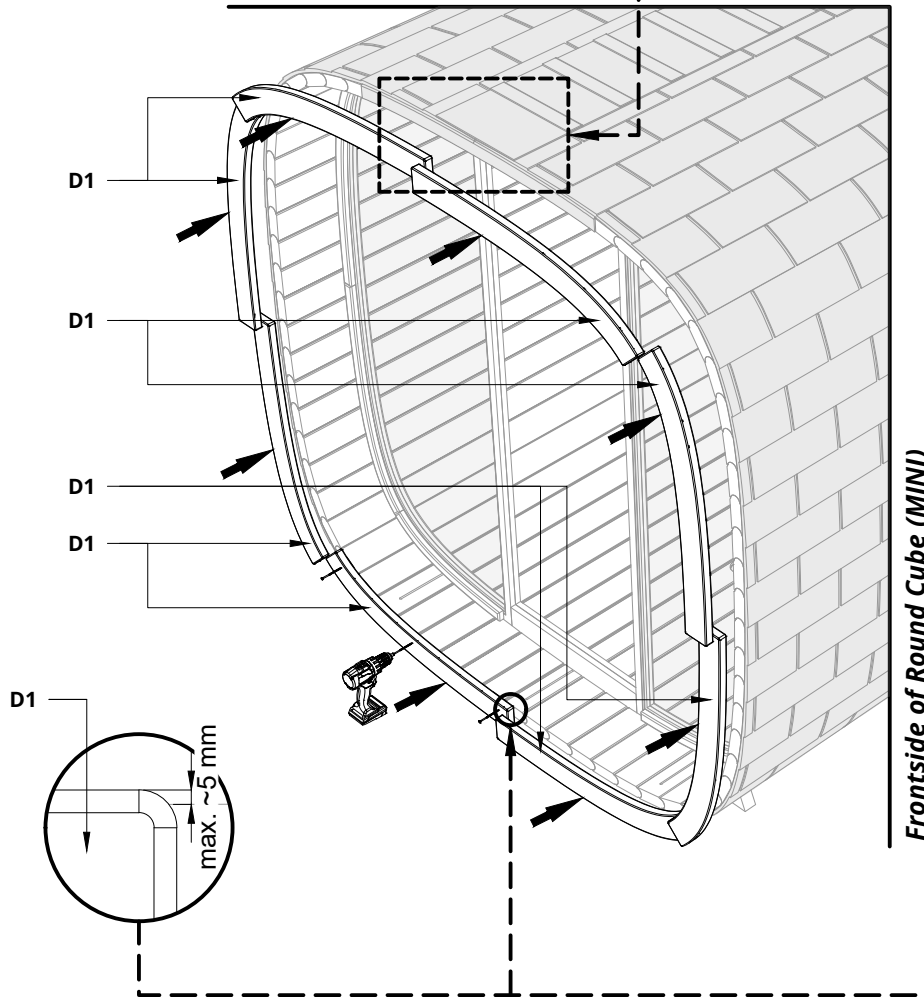
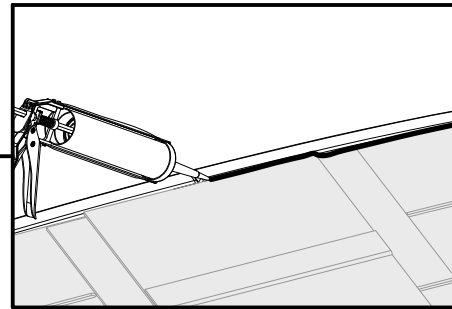
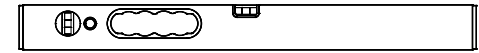

S1	Screws 3x30	18
		

The inner and outer ventilation grilles V2 and adjustable cover V3 are screwed with 3 screws.

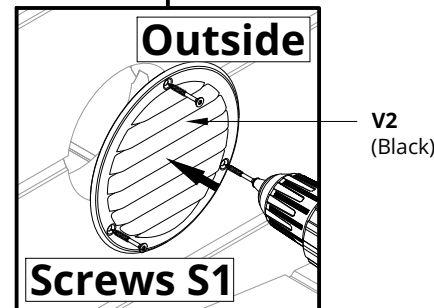
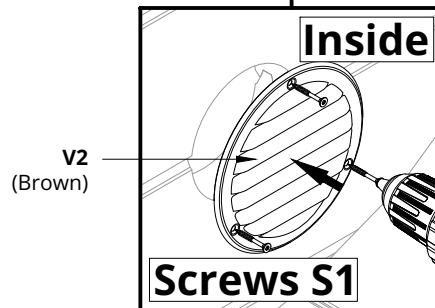
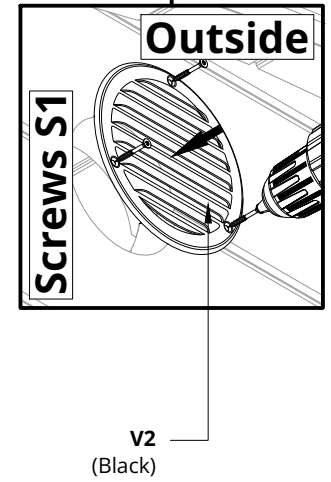
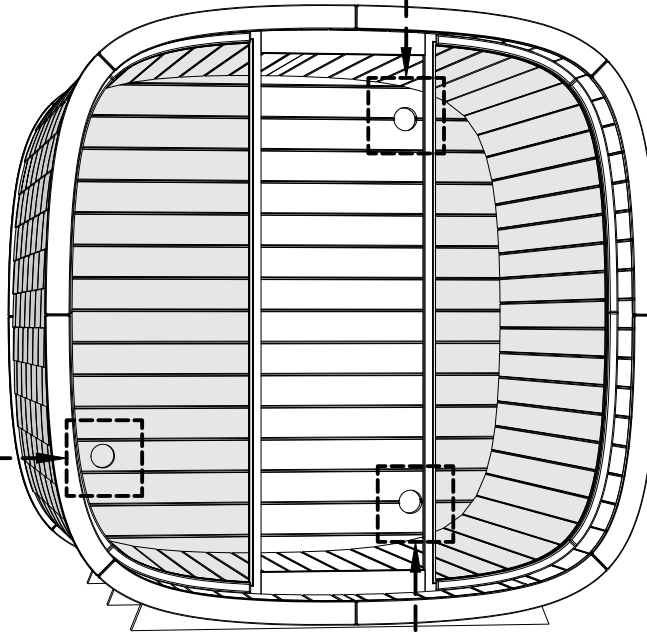
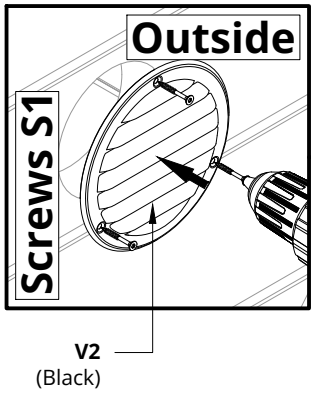
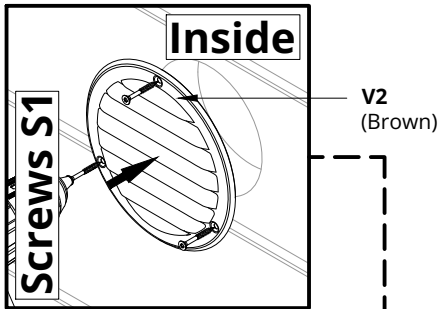
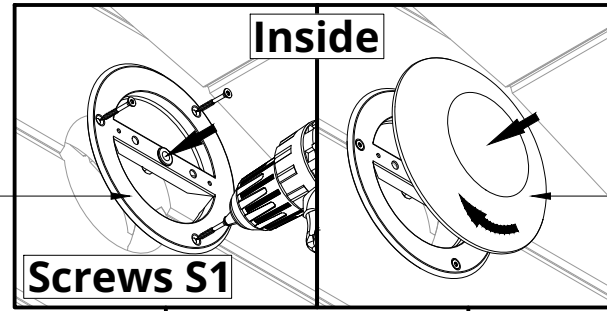
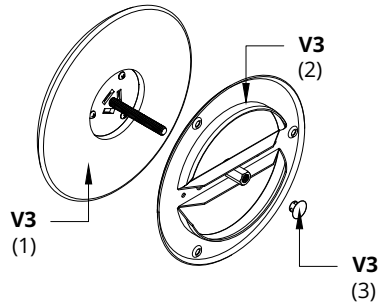

S6.2	Screws 4,2x75	14
S3.2	Screws 4,5x50	14
		

Please countersink the screw head(s)!
Insert hole cover P if they are not attached!
Install the door from the inside,
fasten with screws and install door moldings!

NB! use a level

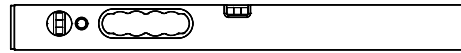

Insert hole cover P if they are not attached!

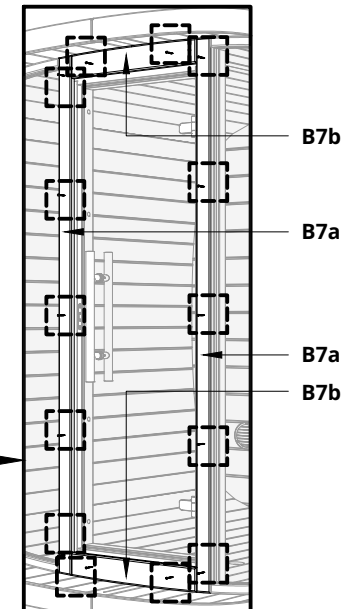
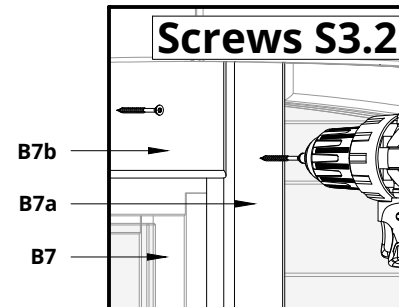
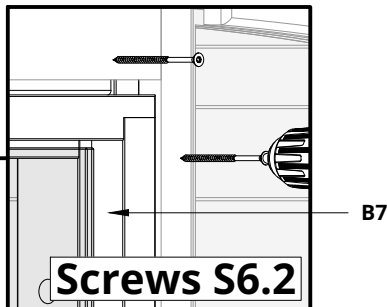
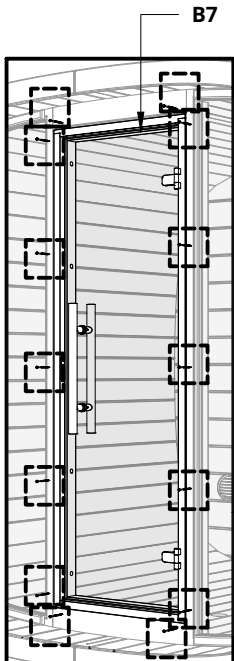
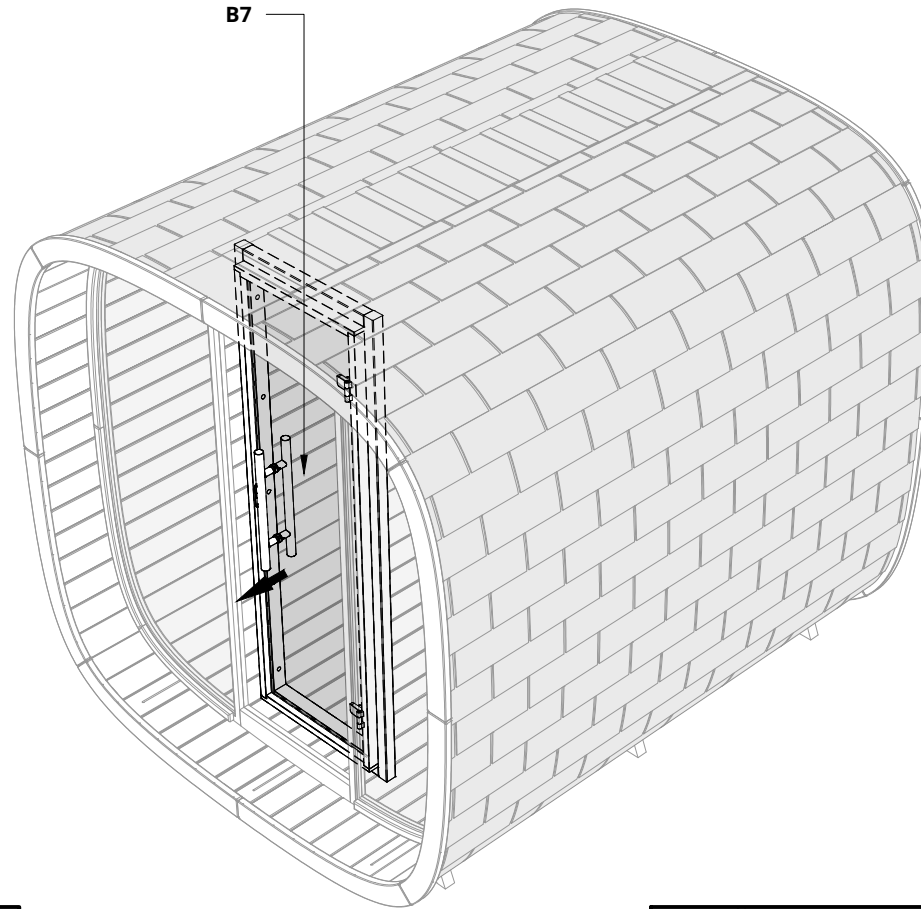
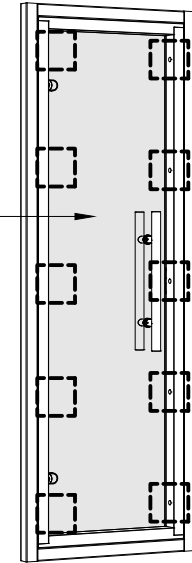
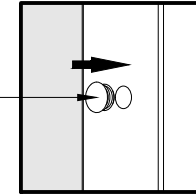

ADJUSTMENT OF THE ROLLER-LOCK

Tools required for adjustment:

- PH2 screwdriver required

Adjustment guide:

- The roller lock can be adjusted by turning the screw indicated by the **red arrow** (shown in Pic.1).
- Turning **clockwise** moves the roller inward (shown by **red arrows** in pic.2) and turning **counter-clockwise** moves the roller outward (shown by **blue arrows** in pic.2).
- The roller should be adjusted so that the **glass moves freely** behind the roller without applying force.
- The roller lock adjustable screw must be always on the upper side of the roll, otherwise the door may get stuck.

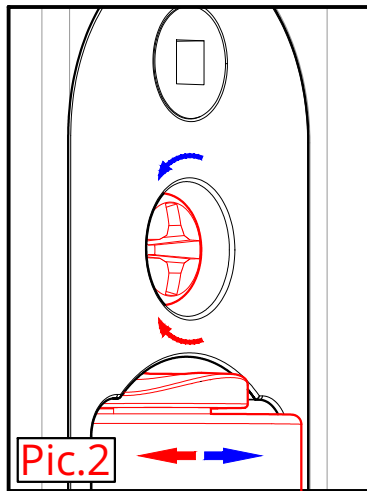
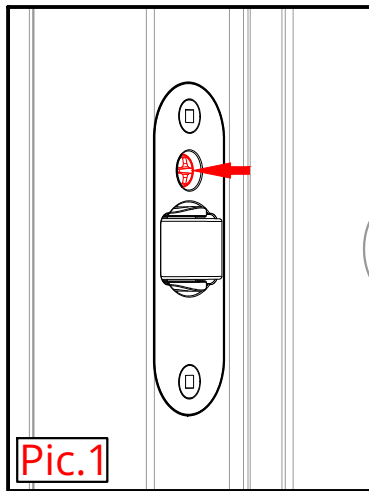

ADJUSTING THE HINGES

Tools required for adjustment:

- T30 (Torx30) Allen wrench or hexagon Bit T30 (Torx30)
- Cordless drill (if Torx Allen wrench is not available)

Adjustment guide:

- Remove plastic from hinges. To remove plastic, start lifting from the locations indicated by the **red arrows** (shown in Pic.1).
- Loosen the bolt slightly (shown in Pic.2). (**DO NOT OPEN COMPLETELY**)
- If both hinge bolts are slightly loosened, then it is possible to move the glass in the directions shown in Pic.3.
- If the glass is set to the required distance, the bolts must be tightened again (shown in Pic.3). **Put the cover back on!**

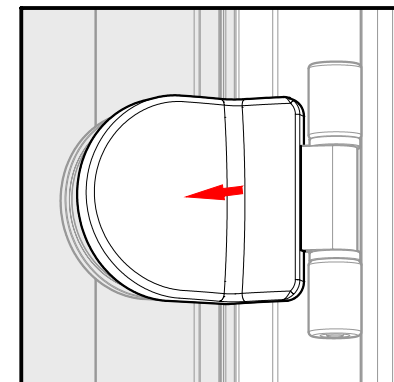
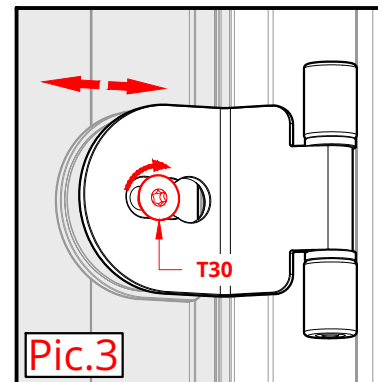
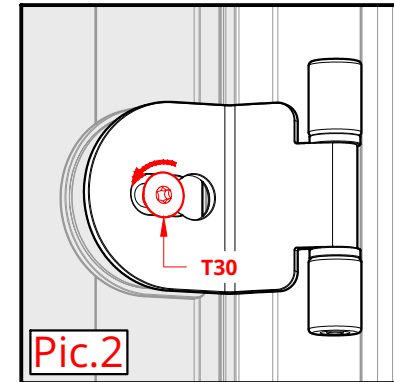
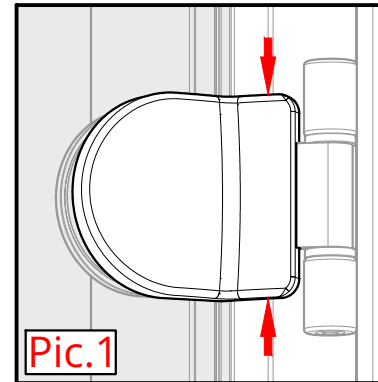

ADJUSTING ABLOY HINGES FOR GLASS DOORS

Features:

- The ABLOY FL 65 SSD Fe is a glass door hinge with lateral adjustment of +/- 3 mm.
- The hinge load capacity is approximately 40 kg when using two hinges.

Tools required for adjustment:

- 5mm Allen wrench or hexagon Bit SW5
- 3mm Allen wrench or hexagon Bit SW3
- Cordless drill (if Allen wrenches (*hexagon wrenches*) are not available)

Adjustment guide:

- Remove the plastic cover from the hinges (*Cover removal, in the direction indicated by the arrow as shown in the Pic.1*). Loosen the bolt slightly (*shown in the Pic.2*) (**DO NOT UNSCREW COMPLETELY**).

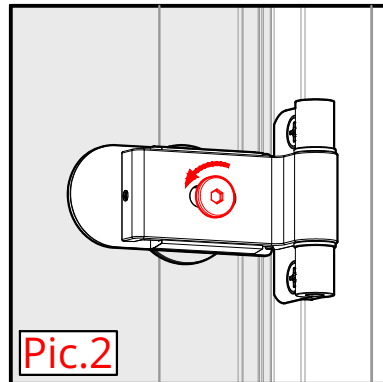
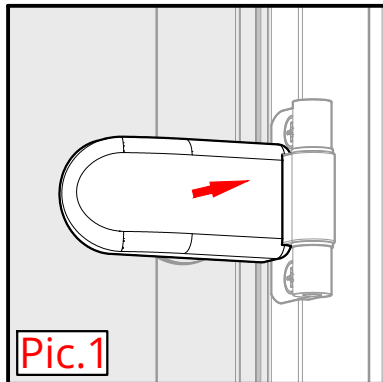

- To adjust the hinges, you need to turn the screws (*shown in the Pic.3 and 4*) with a 3mm allen wrench or a hexagon bit SW3.

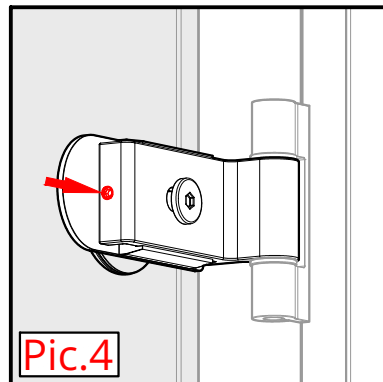
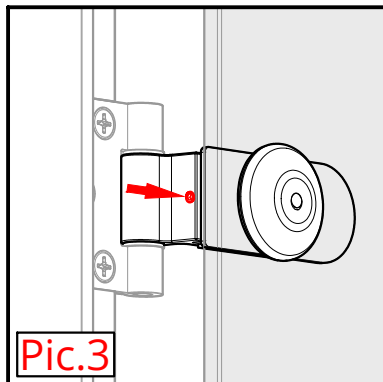

The direction of the glass movement depends on the direction the screw is turned (*assuming the screw on the other side has been loosened*):

- Turning the screw **clockwise** (*shown by red arrows in pic. 5 and 6*), the glass moves closer to the hinges.
- Turning the screw **counterclockwise** (*shown by blue arrows in pic. 5 and 6*), the glass moves away from the hinges.
- Afterwards, tighten the screw on the other side.

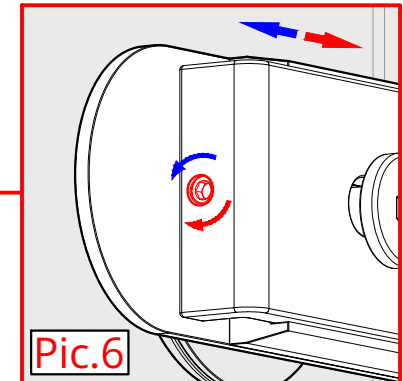
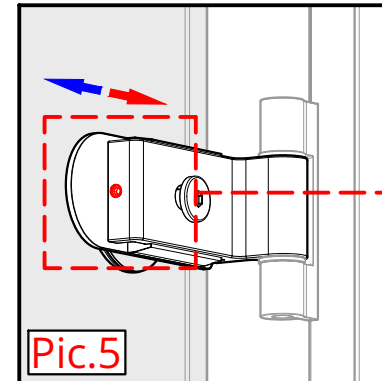

- If the hinges are adjusted, tighten the larger bolt. **Put the cover back on!**

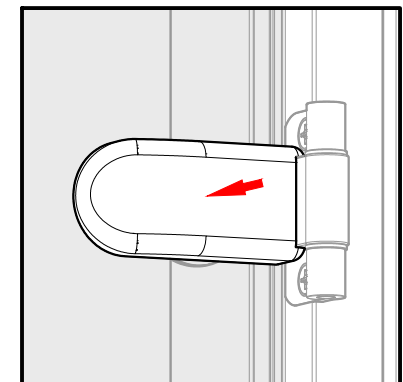
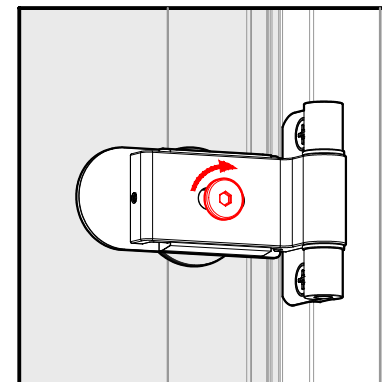

General recommendations:

When adjusting the hinge, it is important to be careful not to damage the glass or the hinge itself.



Round Cube

Bench assembly guide

Round Cube (MINI 2.4)

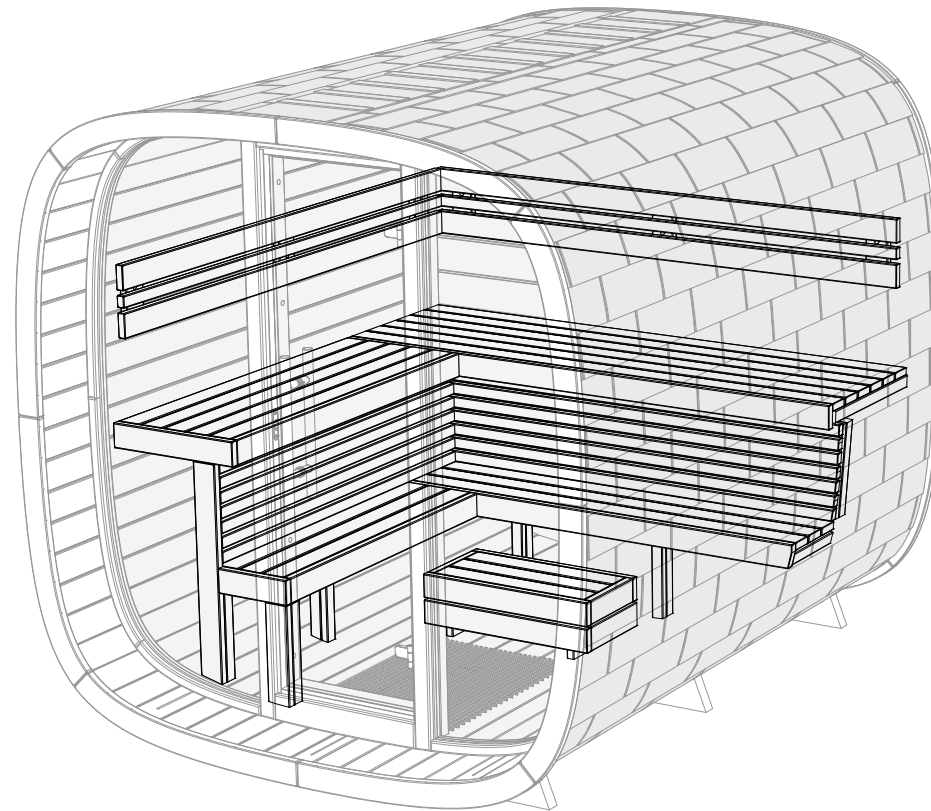

Read the manual and check the parts for completeness before assembly!

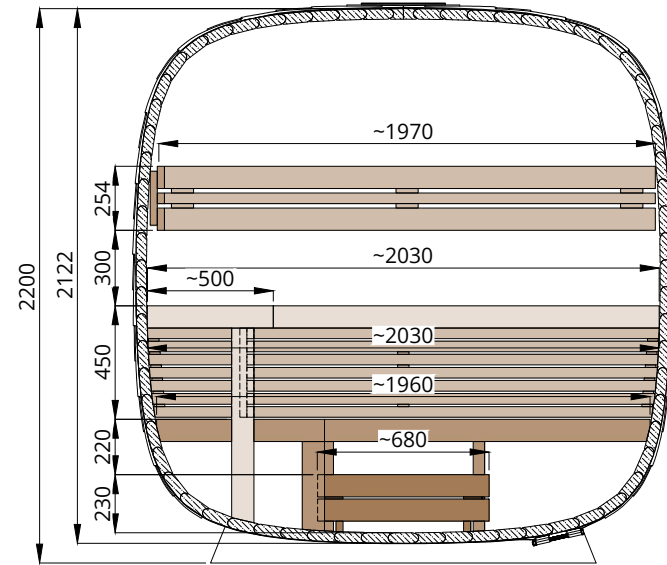
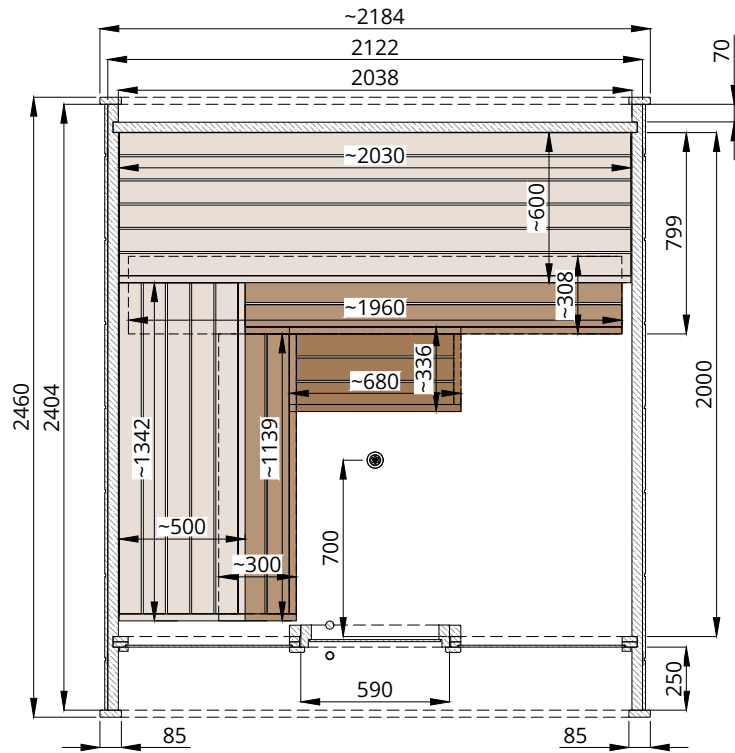

Round Cube

(MINI 2.4)



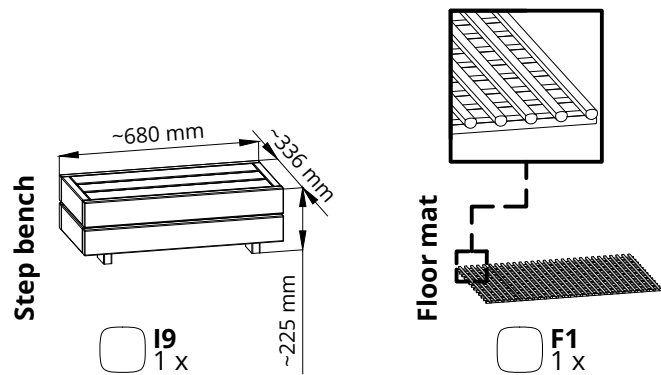
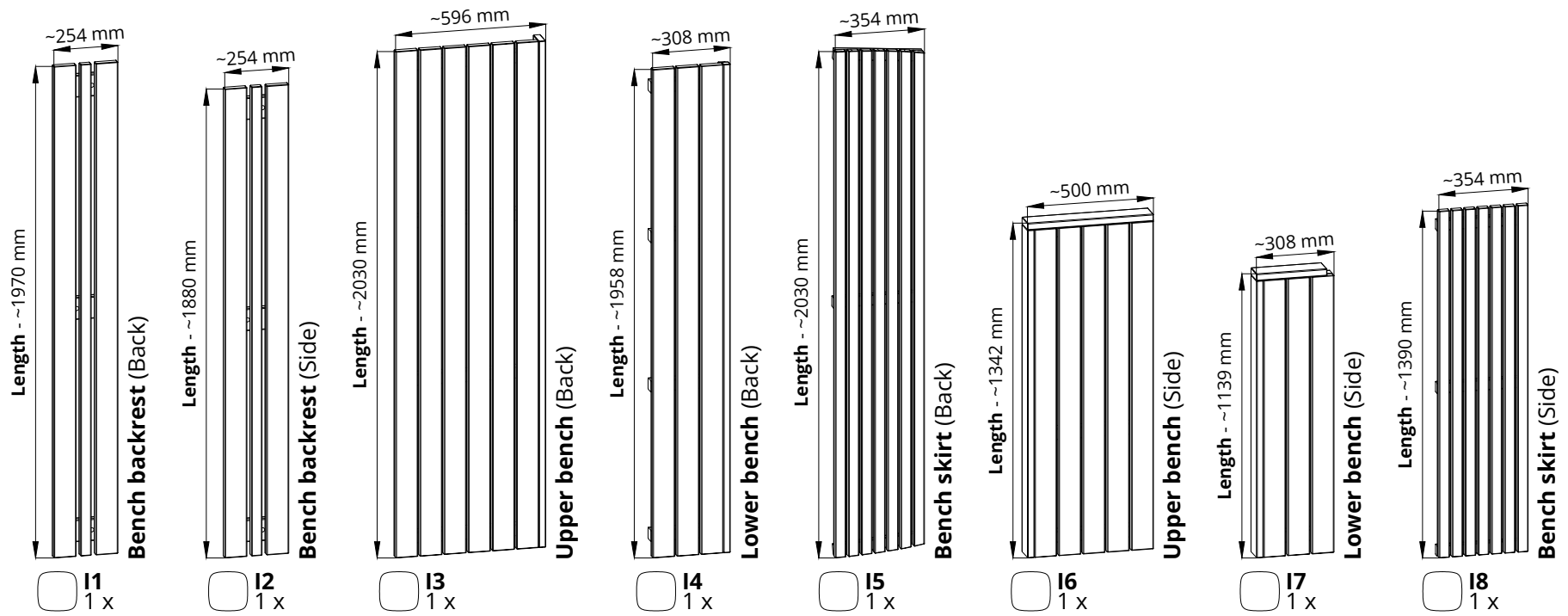

Scale 1 : 30

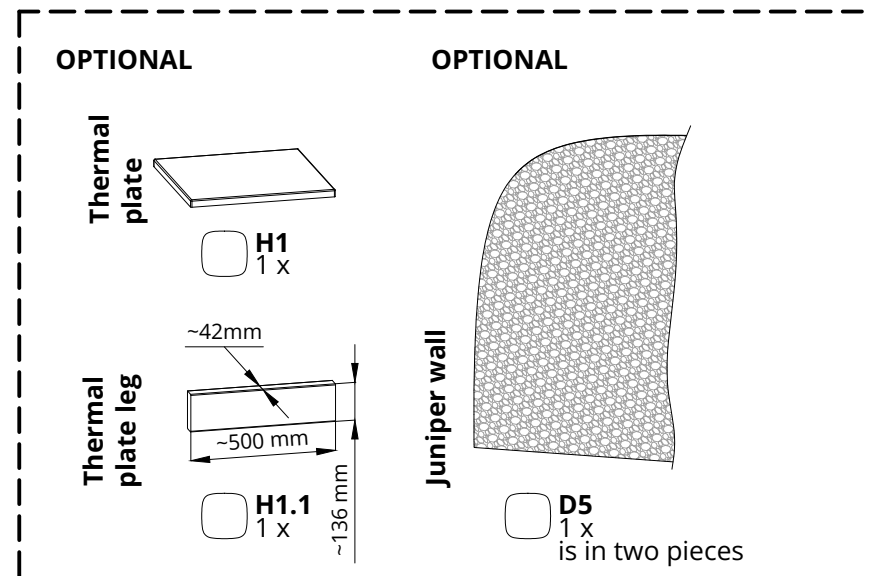

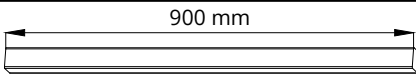
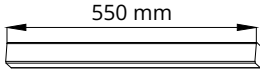
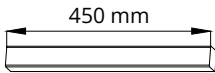
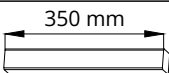
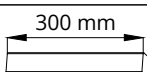
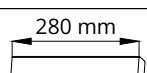
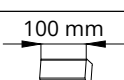
Detail list 1

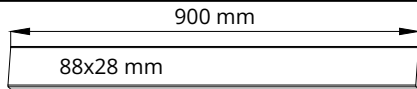
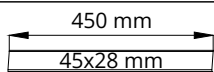
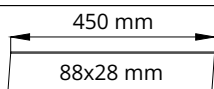

Round Cube		MINI 2.4
Name in manual	K Square woods 45x45mm	
K90		1 <input type="checkbox"/>
K55		2 <input type="checkbox"/>
K45		5 <input type="checkbox"/>
K35		3 <input type="checkbox"/>
K30		1 <input type="checkbox"/>
K28		3 <input type="checkbox"/>
K10		3 <input type="checkbox"/>

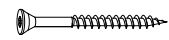
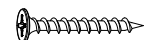
Round Cube		MINI 2.4
Name in manual	Cover boards	
D2		1 <input type="checkbox"/>
D3		5 <input type="checkbox"/>
D4		1 <input type="checkbox"/>
Name in manual	Screws (Scale 1:2)/ Screw size	Qty.
S7	 Screws 4,5x80 for Spruce	40 <input type="checkbox"/>
	 Screws 4,2x75 for Thermo	
S5	 Screws 4,5x60 for Spruce	50 <input type="checkbox"/>
	 Screws 4,2x55 for Thermo	
S2	 Screws 3x40	5 <input type="checkbox"/>
SJ*	 Screws 3.9x32 (Black)	25 <input type="checkbox"/>

* (Optional) for the juniper wall

Detail list 2

S2	Screws 3x40	3
S5	Screws 4,5x60 for Spruce Screws 4,2x55 for Thermo	6
S7	Screws 4,5x80 for Spruce Screws 4,2x75 for Thermo	12



NB! use a level



**Please countersink the screw head(s)!
Height measurements are measured
from a straight surface!
Install the bench backrests I1 and I2!
Install square woods for benches!
Use glue between the square wood
and the wall!**

1. Remove hole cover P if they are attached!
2. Screw the bench backrest
3. Put the hole cover P back

I1 and I2

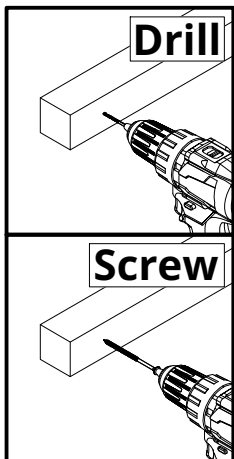
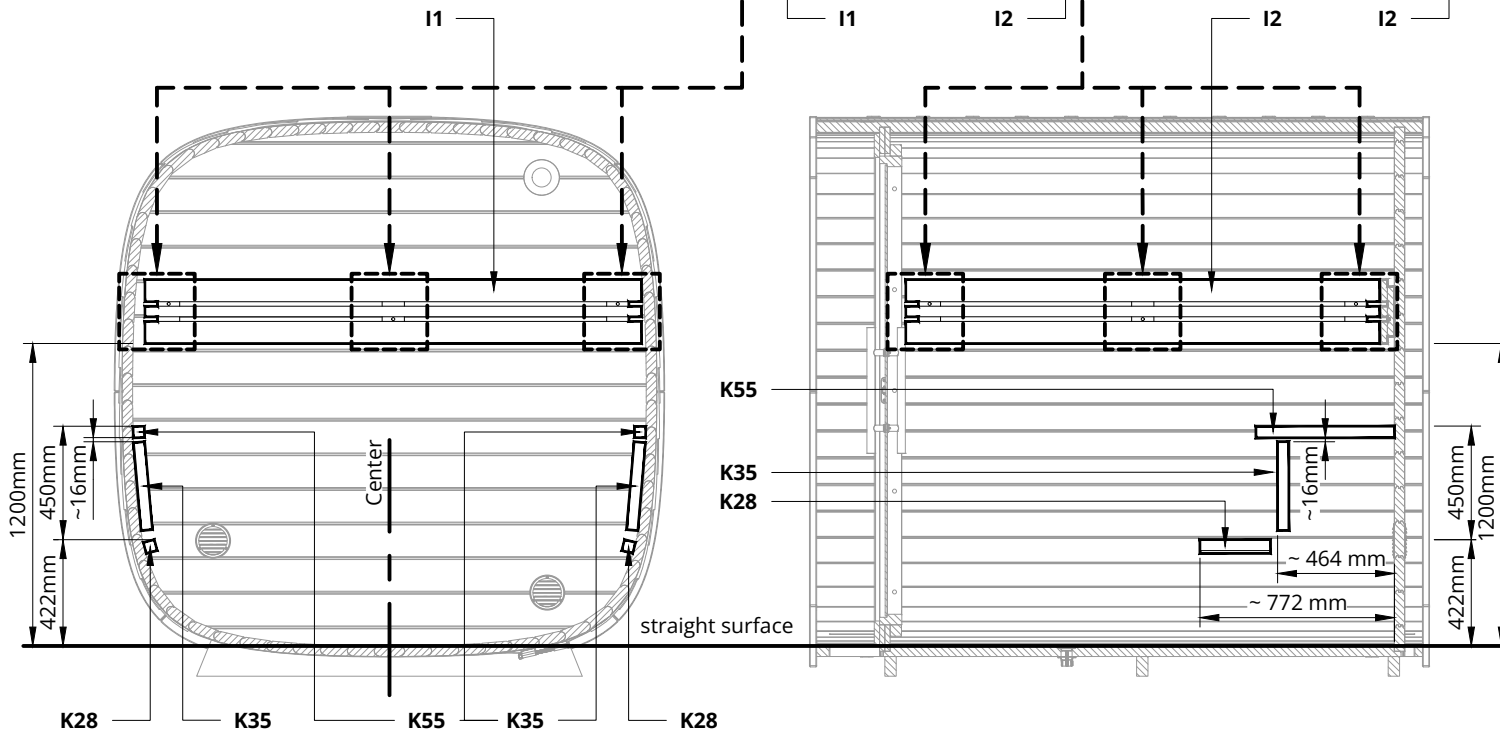
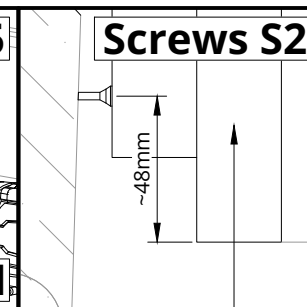
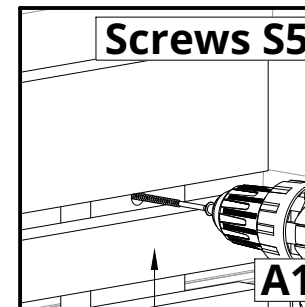
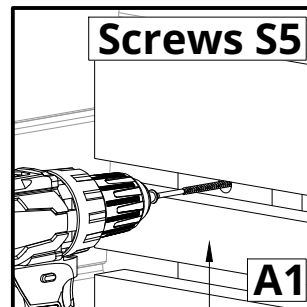
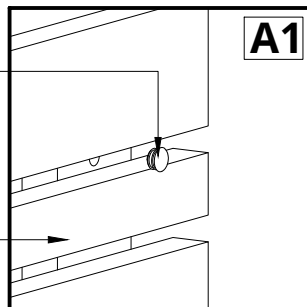

Notice!
Drill 4mm hole in the K.. square woods before screwing.

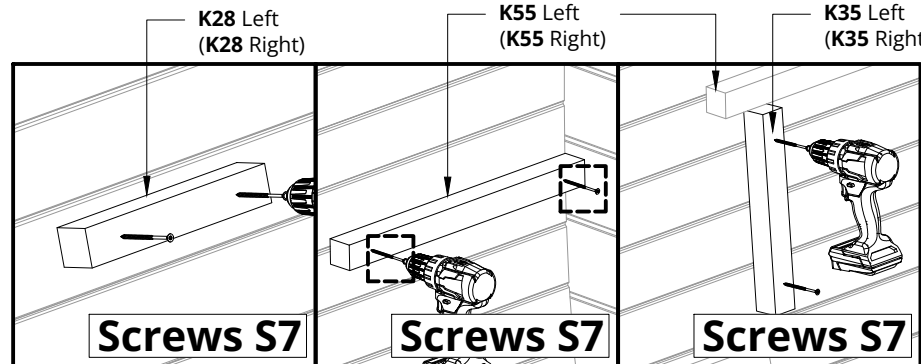
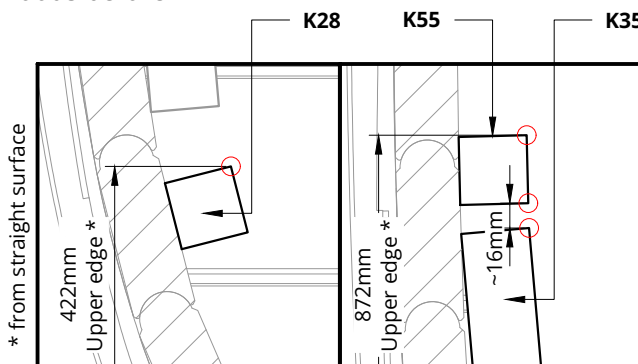

S5	Screws 4,5x60 for Spruce Screws 4,2x55 for Thermo	12
S7	Screws 4,5x80 for Spruce Screws 4,2x75 for Thermo	12
		

Please countersink the screw head(s)!
Install the bench I3 and square wood K10!
Use glue between the square wood and the wall (only K10 square wood)!
Install the bench I4, legs K45 and the legs cover boards D3!
Install benches skirt I8!

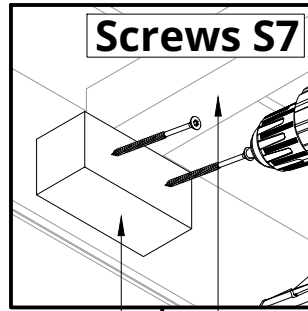

K10 I3

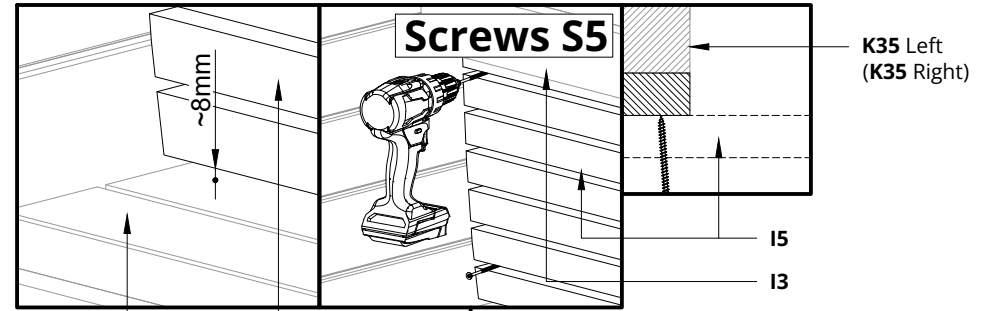

I4 I5

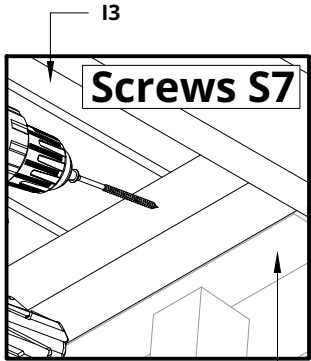

I3
K55 Left (K55 Right)

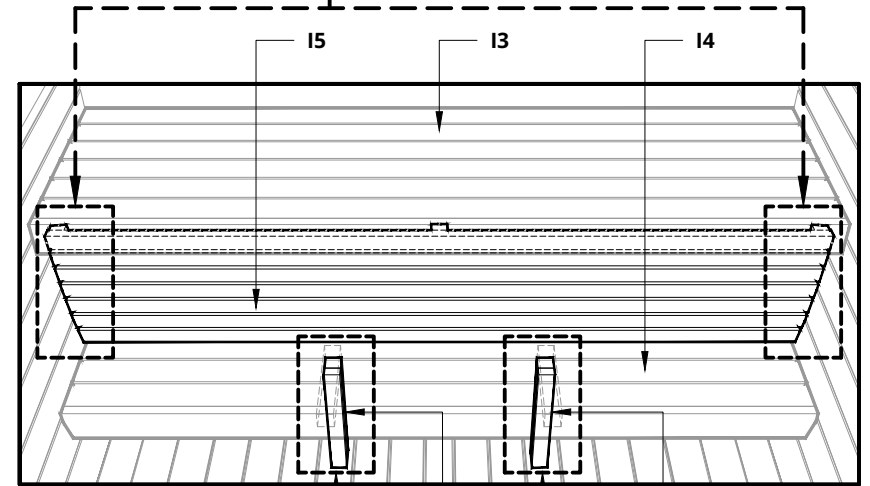
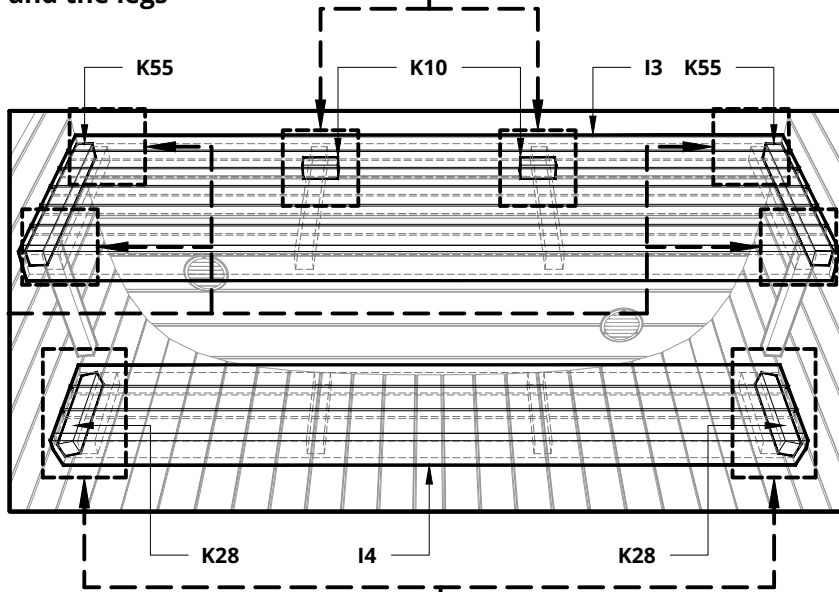

Notice!
 Drill 4mm hole in the K.. square woods before screwing.

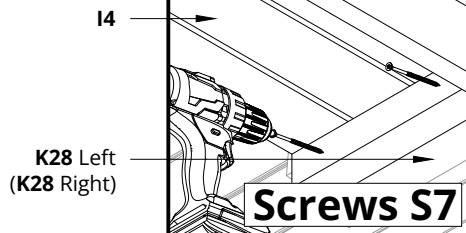
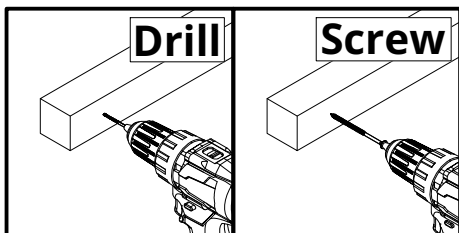

I4
K28 Left (K28 Right)

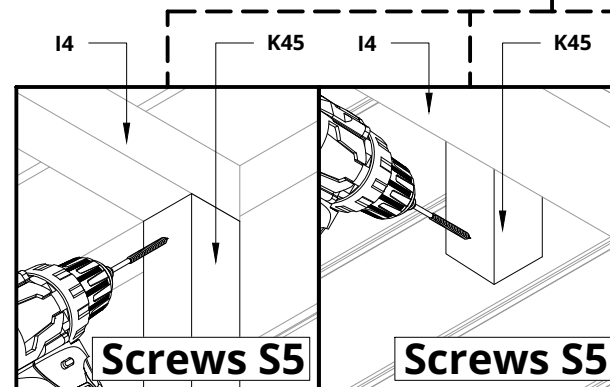

I4 K45 I4 K45 I4 D3
Screws S5

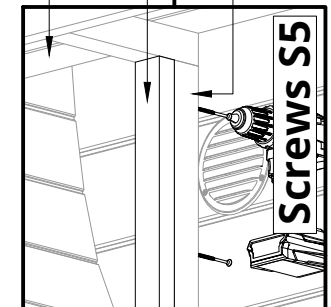

Screws S5

S5	Screws 4,5x60 for Spruce Screws 4,2x55 for Thermo	4
S7	Screws 4,5x80 for Spruce Screws 4,2x75 for Thermo	2
		

NB! use a level

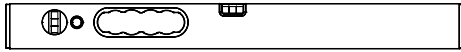

Please countersink the screw head(s)!
Height measurements are measured from a straight surface!
Install square woods for benches!
Use glue between the square wood and the wall!

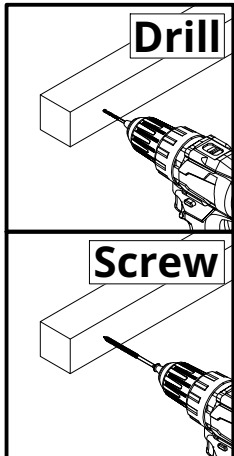
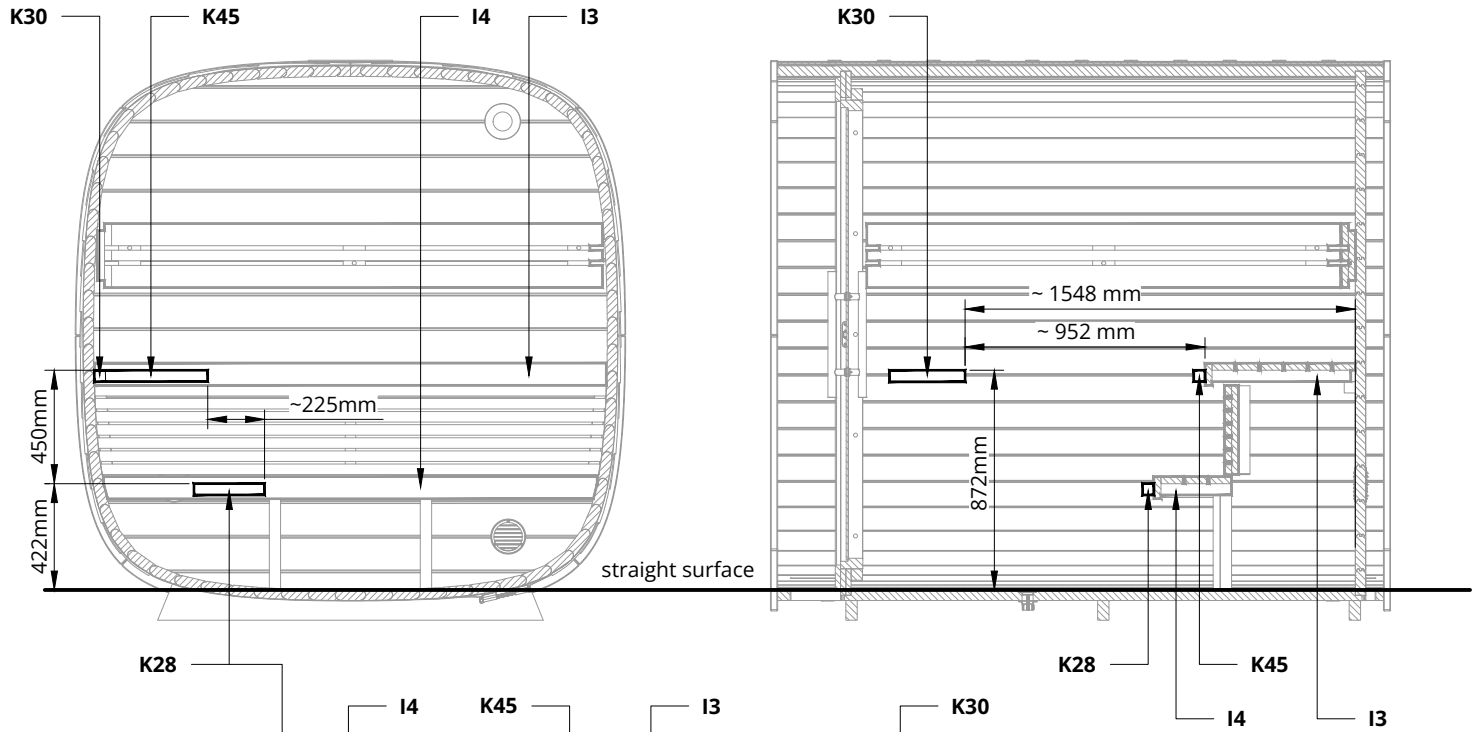
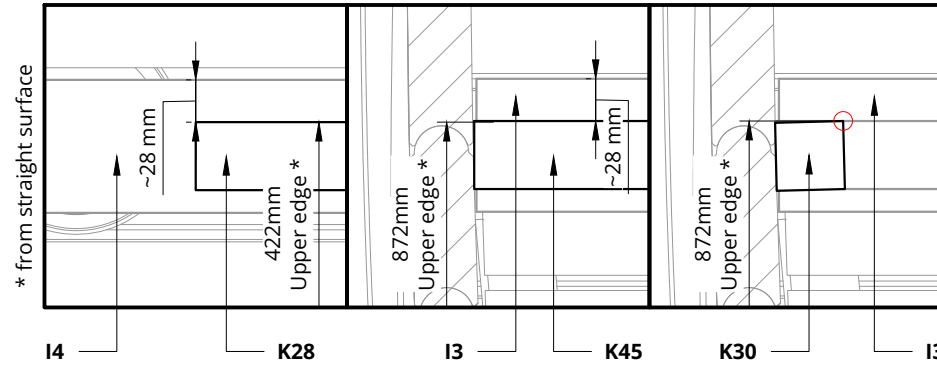

Notice!
 Drill 4mm hole in the K.. square woods before screwing.

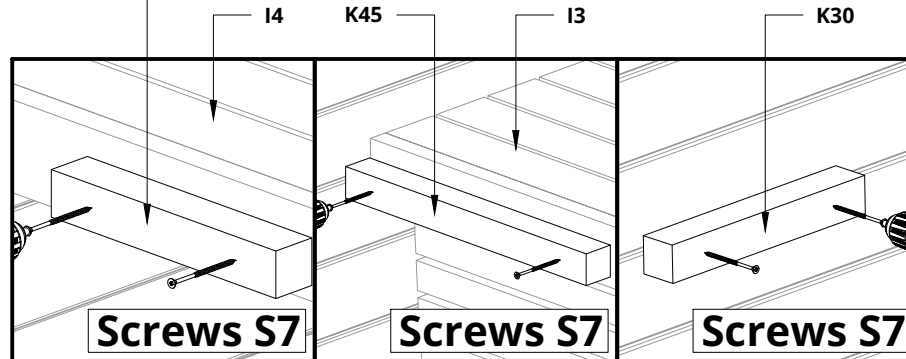

S5	Screws 4,5x60 for Spruce Screws 4,2x55 for Thermo	6
S7	Screws 4,5x80 for Spruce Screws 4,2x75 for Thermo	4
		

NB! use a level



Please countersink the screw head(s)!
The square wood K90 and cover board D2 are longer, they must be cut to the correct size!

Install the bench I6 and some aids to keep the bench level!

Install square woods K10 for bench!

Use glue between the square wood and the wall (only K10 square wood)!

Install the bench leg K90 and the leg cover board D2!

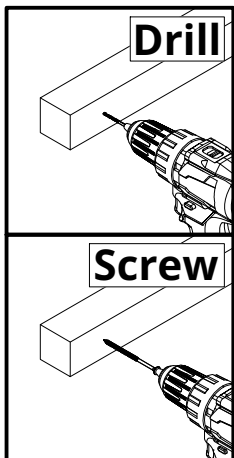
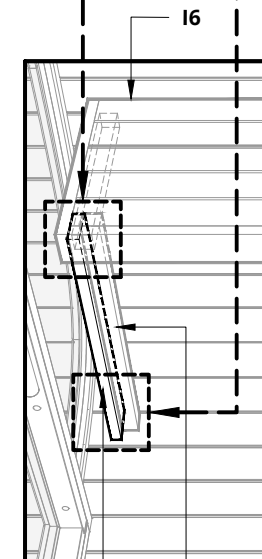
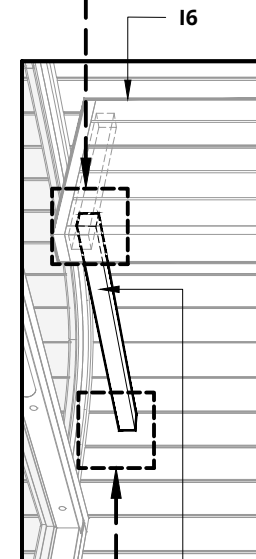
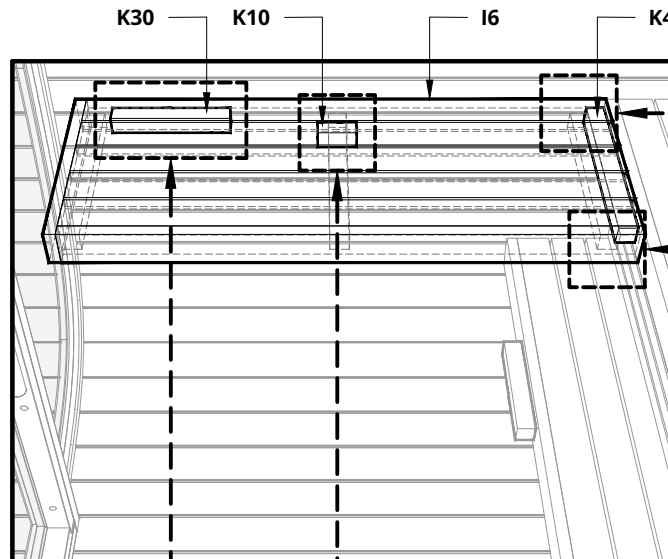
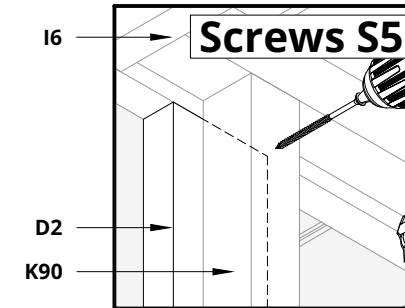
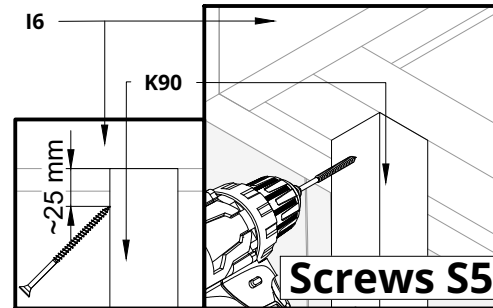
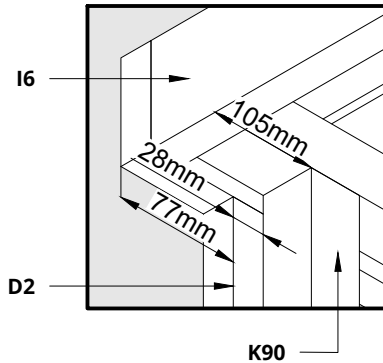

Notice!
 Drill 4mm hole in the K.. square woods before screwing.

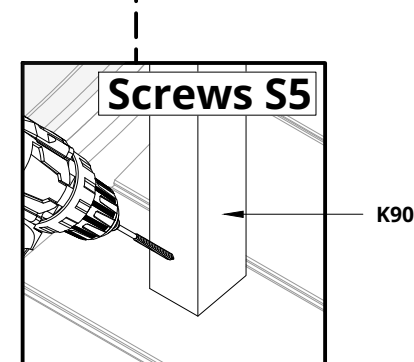
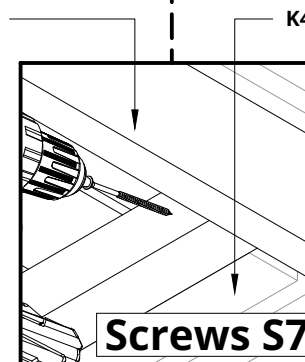
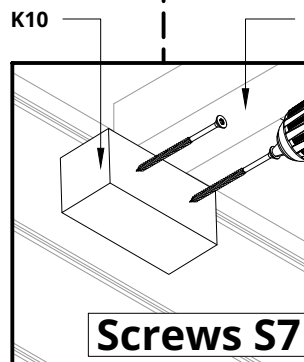
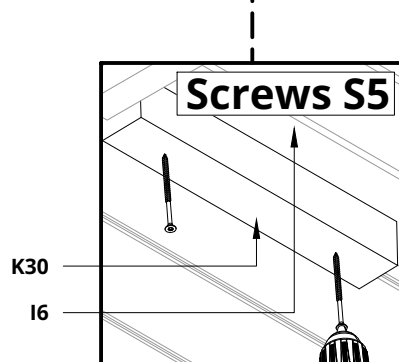

S5	Screws 4,5x60 for Spruce Screws 4,2x55 for Thermo	4
S7	Screws 4,5x80 for Spruce Screws 4,2x75 for Thermo	3
		

NB! use a level

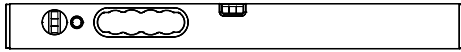

Please countersink the screw head(s)!
Height measurements are measured from a straight surface!

The square wood K45 and cover boards D3 are longer, they must be cut to the correct size!

Install the bench leg cover board D3!
Install the bench I7 and some aids to keep the bench level!

Install the bench leg K45!

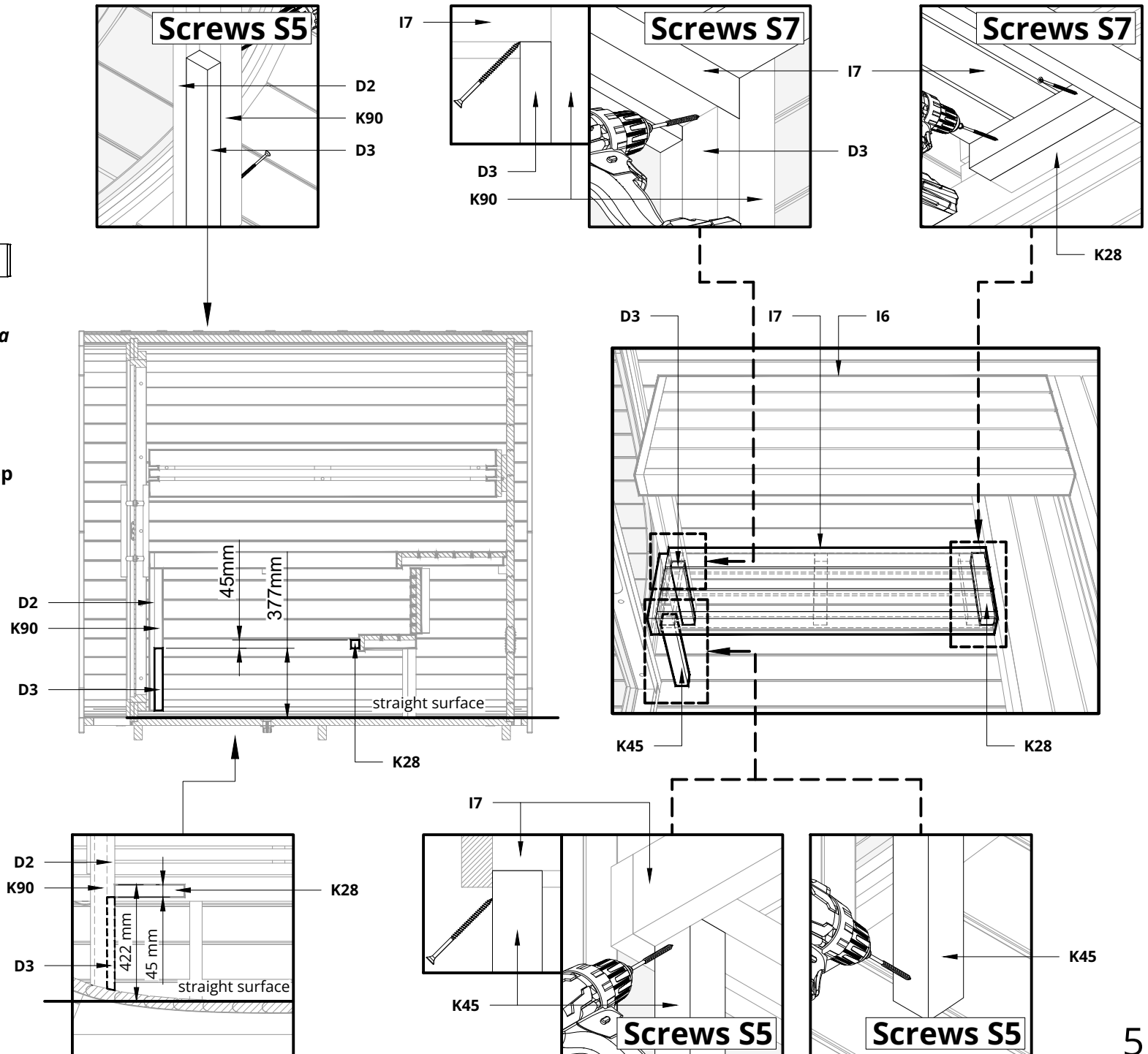

S5	Screws 4,5x60 for Spruce Screws 4,2x55 for Thermo	8
----	--	---



NB! use a level

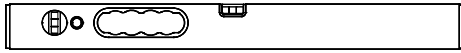

Please countersink the screw head(s)!
The square wood K45 and cover boards D3 and D4 are longer, they must be cut to the correct size!
Install the bench leg K45 and the leg cover boards D3 and D4!

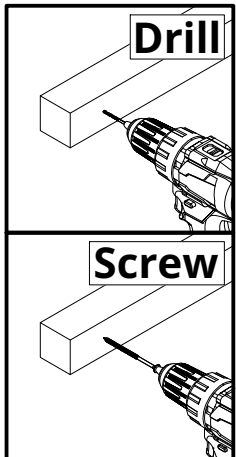
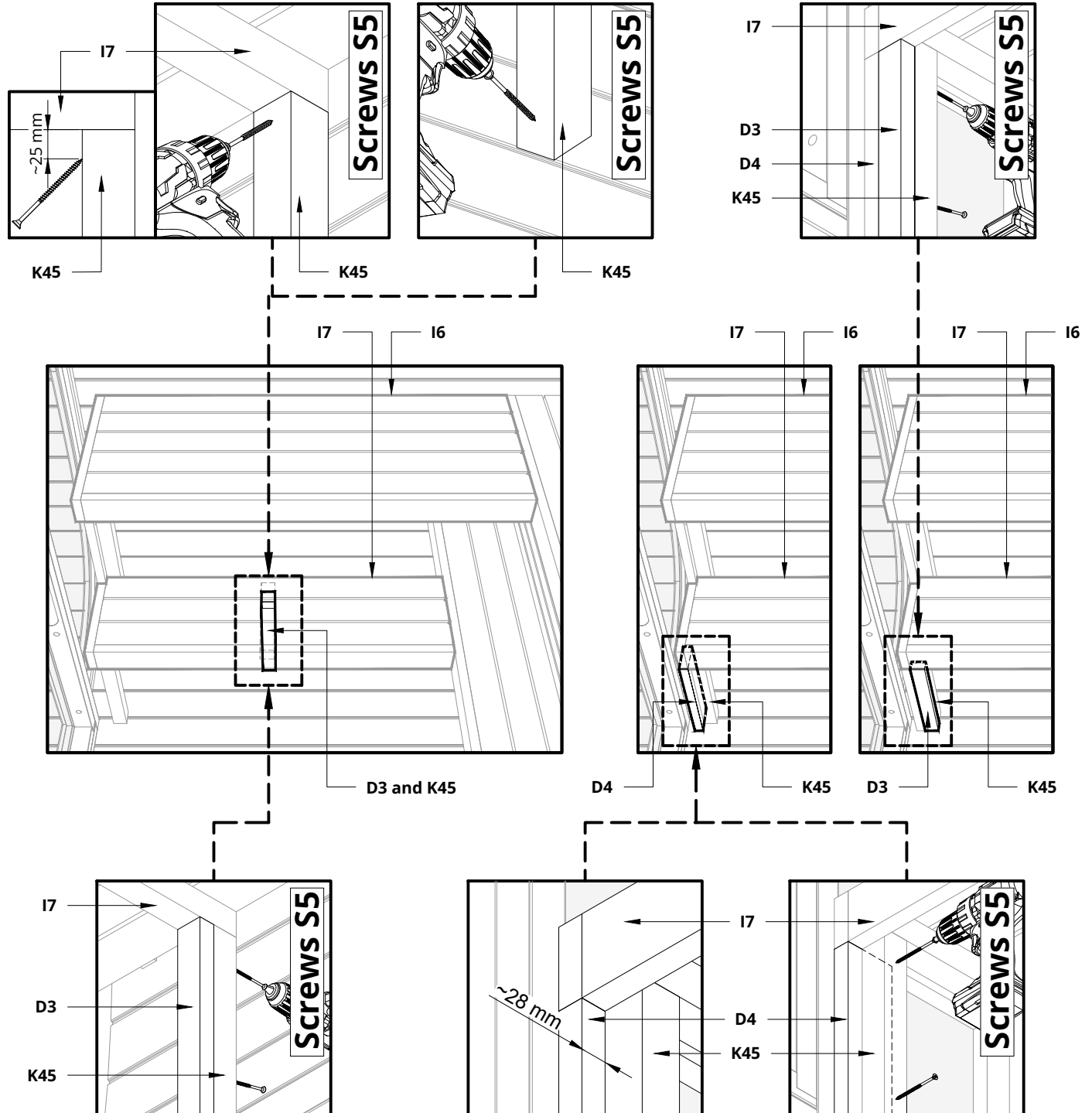

Notice!
 Drill 4mm hole in the K.. square woods before screwing.

S5	Screws 4,5x60 for Spruce Screws 4,2x55 for Thermo	6
		

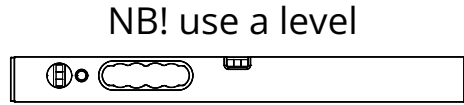

Please countersink the screw head(s)!
First measure and mark the distance for K35!
Install square woods K35 and bench skirt I8!

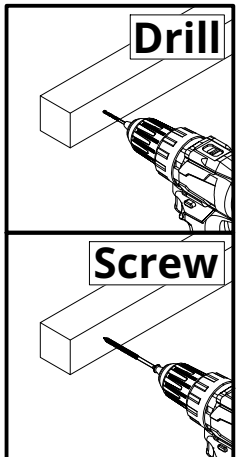
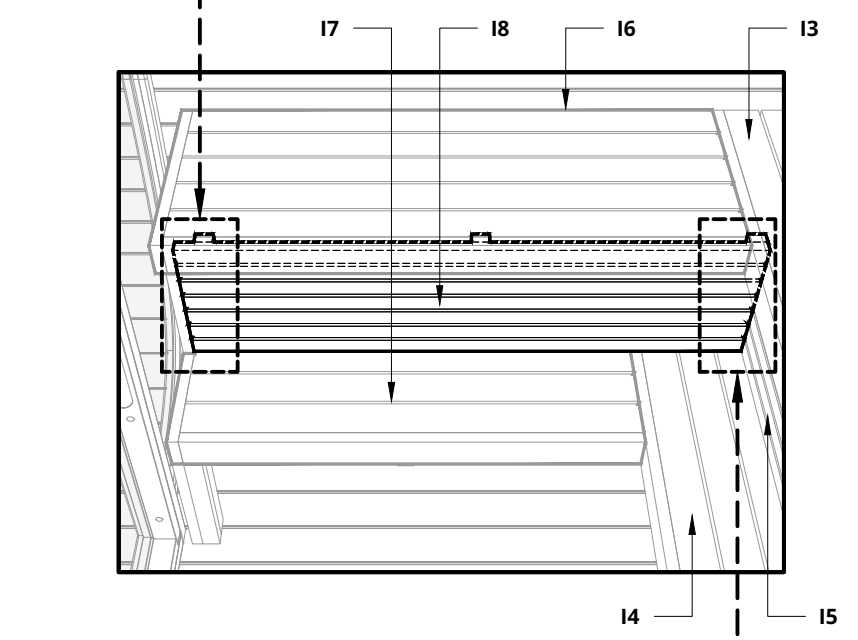
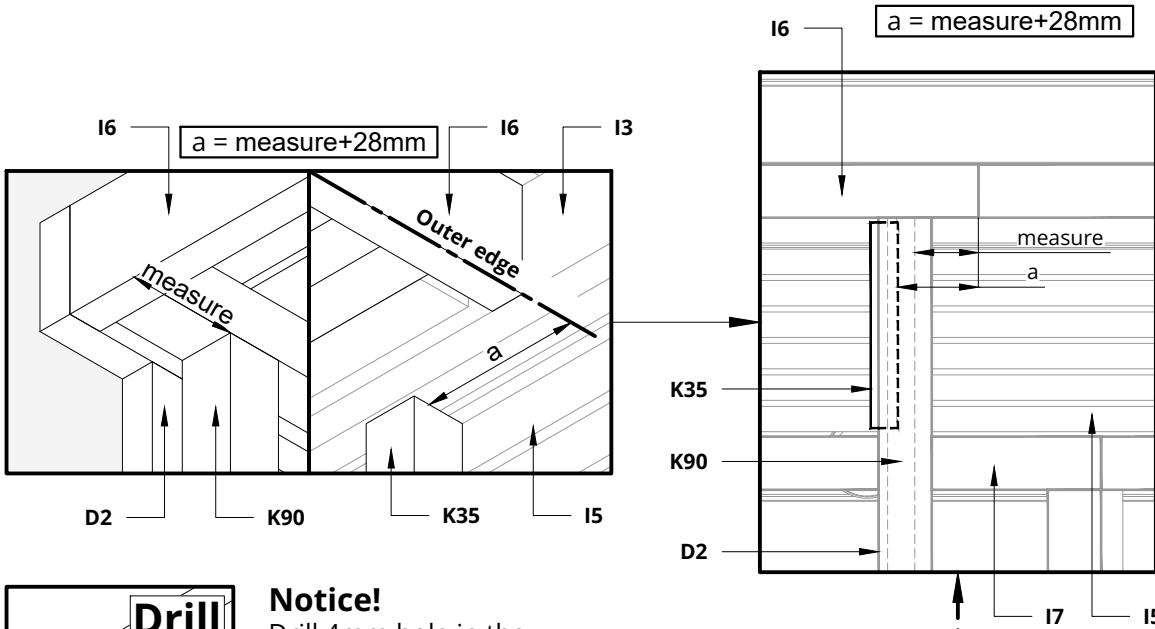
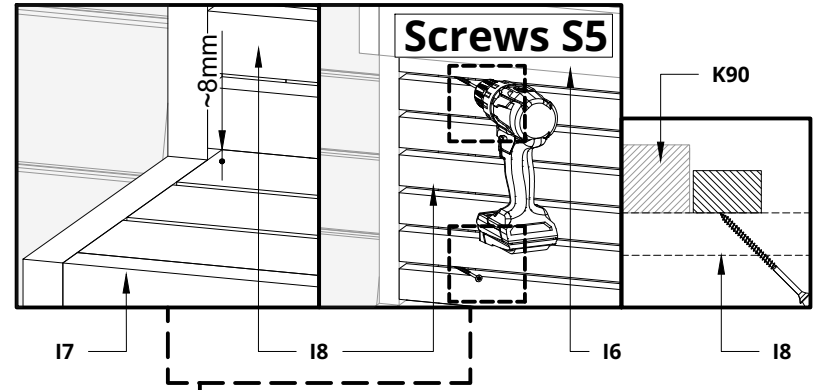

Notice!
 Drill 4mm hole in the K.. square woods before screwing.

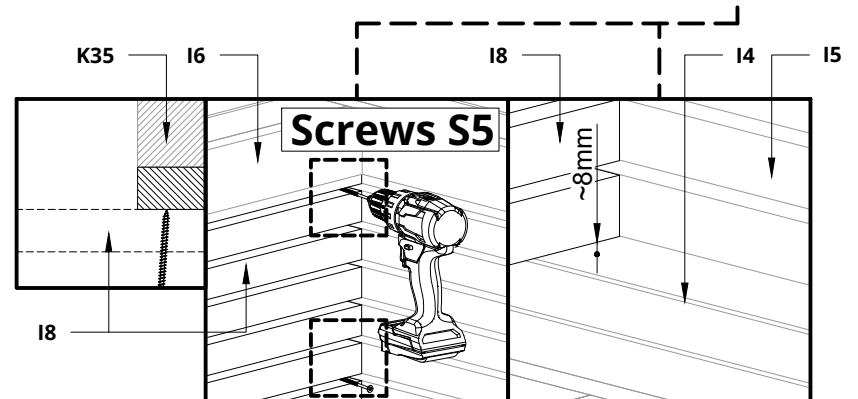
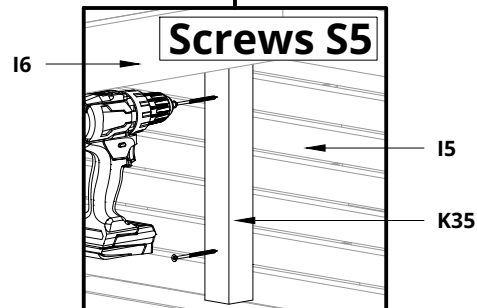

S5	Screws 4,5x60 for Spruce Screws 4,2x55 for Thermo	3
S7	Screws 4,5x80 for Spruce Screws 4,2x75 for Thermo	3
		

NB! use a level

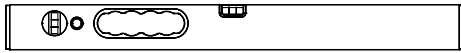

(Optional)
These steps are applicable to thermal protection plate if it is ordered

Install the leg H1.1 of the thermal protection plate H1!
Drill 5 mm holes in the thermal protection plate H1 and install it!
(The hole locations are shown in picture.)

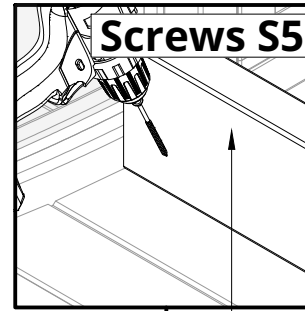
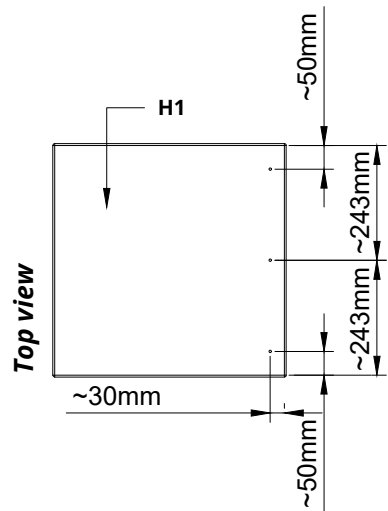

H1.1

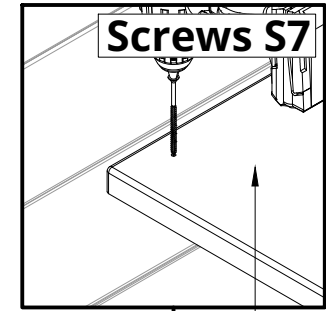

H1

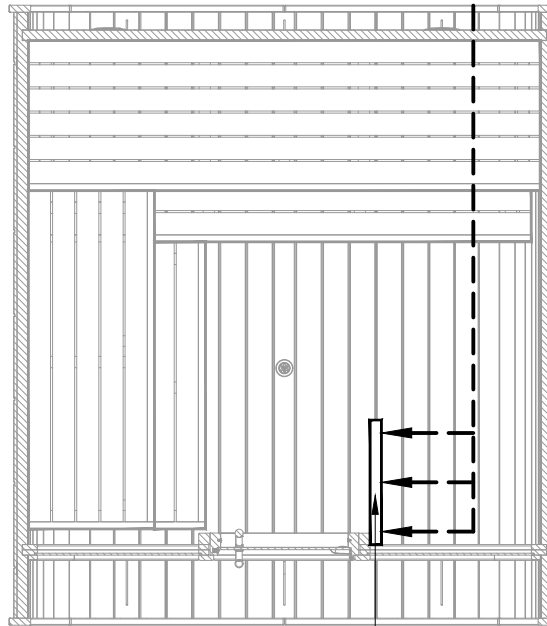

H1.1

H1.1

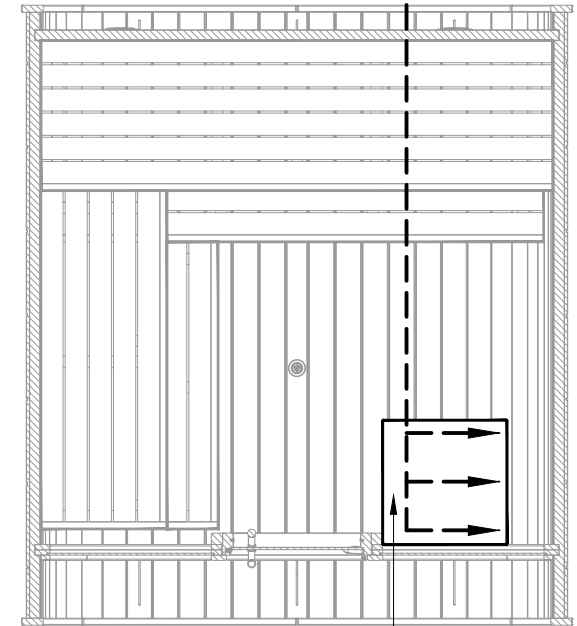
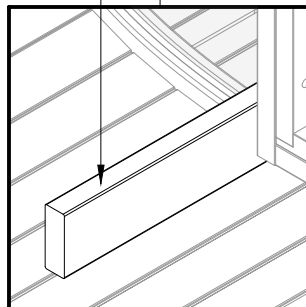

H1

H1

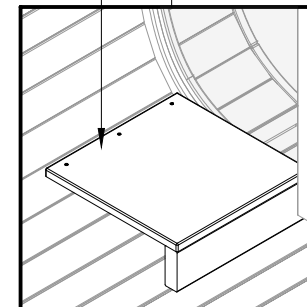

Install the step bench I9!
Place the floor mat F1!

